



arada  
— stoves —

# Farringdon

**PLEASE RETAIN THIS GUIDE FOR FUTURE REFERENCE**

EN 13240:2011 +A2:2004

## Arada Farringdon Stove User Guide

Congratulations on the purchase of your new Arada stove!

More than 30 years of experience has been put into the development of your stove to ensure ultimate performance and years of trouble free use and enjoyment. Every detail of your stove has been carefully designed and engineered which is why we are so confident in the reliability of our products.

Your Arada stove is built to the highest standard of craftsmanship using the best materials and the most modern equipment available. It is a highly efficient and sophisticated piece of machinery and when properly installed and operated it should provide a lifetime of heating satisfaction.

Should you have any questions about your stove which are not covered by this manual, please contact the Arada retailer in your area, call our technical support department on +44 (0)1297 35700 or visit our website [www.aradastoves.com](http://www.aradastoves.com) which offers a wealth of information on how to care for, and get the best from your stove.

Please ensure that you read these instructions in full and understand them before operating your stove.

Arada has a policy of continuous product development and therefore we reserve the right to amend specifications without prior notice. Due to printing cycles, items or options may be described before they are generally available or after they have ceased. Please check with your retailer or dealer if you are unsure about any aspect of your stove, its installation or correct use.

---

# Contents

<b>1 Identifying your stove</b>	
1.1 Identifying parts & terminology of your stove—External.....	5
1.2 Identifying parts & terminology of your stove—Internal .....	6
<b>2 Warnings</b>	
2.1 Important Warnings .....	7
2.2 Health and Safety .....	8
2.3 Smoke control areas .....	8
<b>3 Recommended fuels</b>	
3.1 Wood .....	9
<b>4 Before using your stove</b> .....	10
<b>5 Air inlet controls</b>	
5.1 Air inlet .....	11
5.1.1 Primary air control location.....	11
5.1.2 Primary air control .....	12
5.1.3 Tertiary air .....	12
<b>6 Lighting your stove</b>	
6.1.1 Smoke control areas .....	13
6.1.2 Fuel overloading .....	13
6.1.3 Operation with door left open .....	13
6.1.4 Dampers / Air controls left open .....	13
6.2 Burning wood .....	13
6.3 Burning solid fuel.....	14
6.4 Warning - Fume / Smoke emissions .....	14
6.5 Refuelling on to a low fire bed .....	15
6.6 Typical wood burn for nominal output .....	15
<b>7 Further information for all stove owners</b>	
7.1 Door glass .....	16
7.2 Reduced burning (Slow combustion).....	16
7.3 Over firing .....	16
7.4 Chimney fires .....	16
7.5 Ash removal .....	17
7.6 Periods of non-use (summer months).....	17
7.7 Classification .....	17
7.8 Adverse weather conditions .....	17
7.9 Replacement parts .....	18

<b>8 Further information for multi fuel stove owners</b>	
8.1 <i>Flexifuel</i> grates bars.....	18
<b>9 How heat is delivered by your stove</b>	
9.1 Radiant heat .....	19
<b>10 Care for your Arada stove</b>	
10.1 Adjusting the door hinges .....	20
10.2 Liners / firebricks .....	20
10.3 Throat plate .....	20
10.4 Fire door seal .....	21
10.5 Cracked glass .....	21
10.6 Chimney / flue sweeping .....	21
<b>11 Further resources / reading</b>	
11.1 Information.....	22
11.2 Specifications .....	22
<b>12 Guarantee</b>	
12.1 Guarantee .....	23
12.2 Terms and Conditions .....	23-24
12.3 General .....	25
<b>13 Technical data</b> .....	26
<b>14 Notes</b> .....	27

# 1 Identifying your stove

## 1.1 Identifying parts & terminology of your stove—External

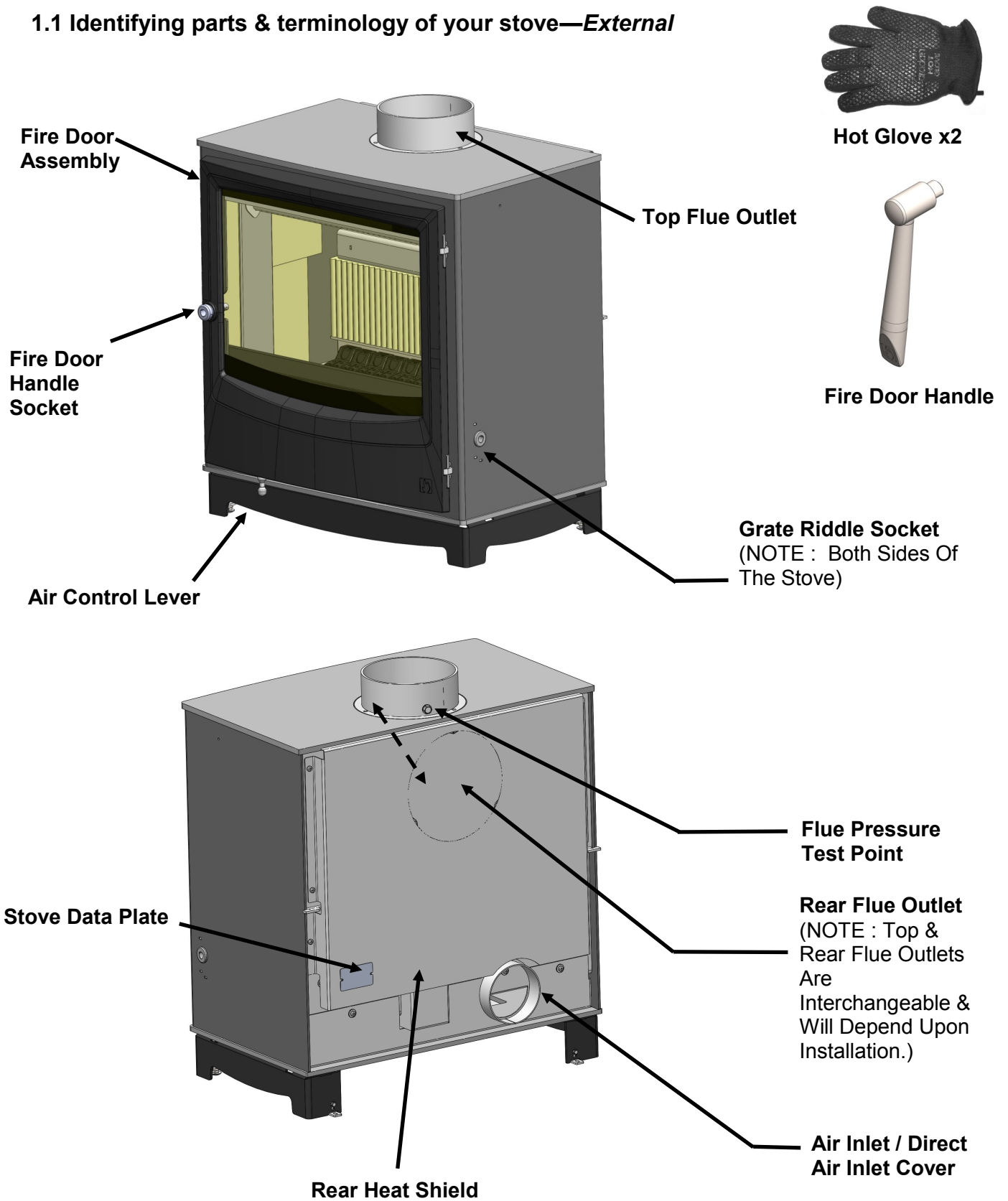

1.2 Identifying parts & terminology of your stove—*Internal*

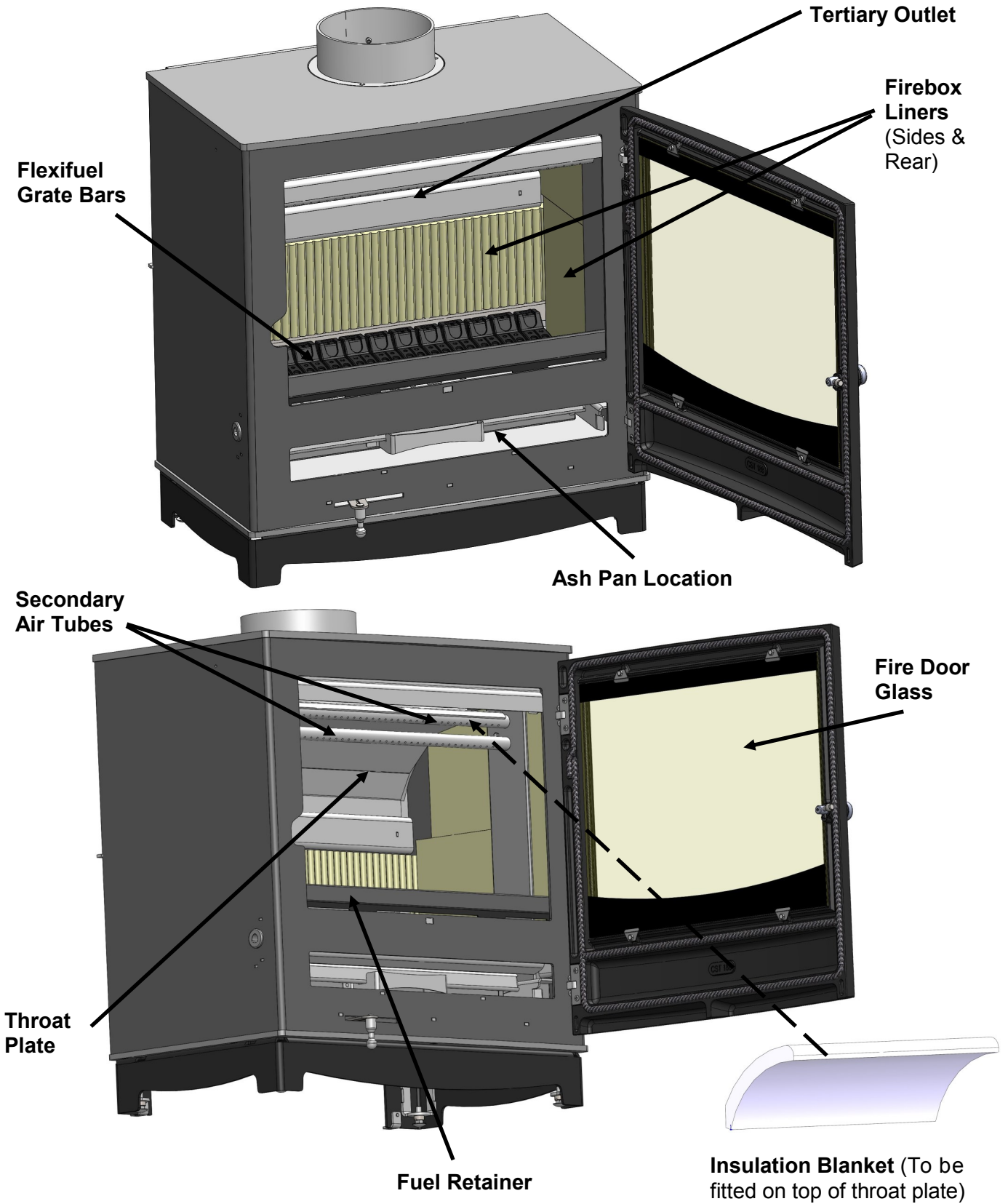



## 2 Warnings

### 2.1 Important Warnings

It is a LEGAL REQUIREMENT that the installation of all new or replacement, wood or solid fuel heating appliance, obtain building control approval from your local authority or the installation work must be carried out through a government approved competent persons scheme. A list of all competent person schemes can be found :  
<https://www.gov.uk/guidance/competent-person-scheme-current-schemes-and-how-schemes-are-authorized>

Any manufacturer's instructions must not be taken as overriding statutory requirements.

All Arada Farrington stoves MUST NOT be connected to a shared flue system.

Please Note: Classification of these appliances is for intermittent use only.

Do not use aerosol sprays or any other flammable materials near the appliance when in use.

Do not use the appliance as an incinerator.

Use only recommended fuels, STRICTLY NO unsuitable and non recommended fuels or materials or liquid fuels allowed.

Pure petroleum coke or Bituminous house coal must NOT be burned in this appliance. The use of these fuels will invalidate the appliance guarantee.

Please ensure that the air inlet vent grills to the dwelling are not obstructed or liable to be blocked.

Caution must be exercised during operation of the appliance as both internal and external surfaces will be hot to touch, use the stove mitten provided when the appliance is in operation.

A fireguard conforming to BS 8423:2002 should be used in the presence of children or elderly people.

Always observe the distances to combustible materials as stated on the appliance data plate and in the technical data section of this manual. Ensure no soft furnishings or combustible materials are susceptible to heat radiating from the appliance.

Under NO circumstances should the stove be operated for extended periods with the main fire door open. This will result in an over firing situation and will lead to severe damage to the stove and flue system.

Ignoring the warnings could lead to damage/injury to persons and/or property.

Arada Ltd will not be responsible for any consequential or incidental loss or injury however caused.

## 2.2 Health and Safety

Please consult health and safety guidelines for advice on handling heavy and / or large items.

## 2.3 Smoke control areas (The Clean Air Act 1993 & Smoke Control Areas)

Under the Clean Air Act local authorities may declare the whole or part of the district of the authority to be a smoke control area. It is an offence to emit smoke from a chimney of a building, from a furnace or from any fixed boiler if located in a designated smoke control area. It is also an offence to acquire an “unauthorised fuel” for use within a smoke control area unless it is used in an “exempt” appliance (“exempted” from the controls which generally apply in the smoke control area).

In England appliances are exempted by publication on a list by the secretary of state in accordance with changes made to section 20 and 21 of the *Clean Air Act 1993* by section 15 of the Deregulation Act 2015. Similarly in Scotland appliances are exempted by publication on a list by Scottish Ministers under section 50 of the Regulatory Reform (Scotland) Act 2014.

In Wales and Northern Ireland these are authorised by regulations made by Welsh Ministers and by the Department of the Environment respectively.

Your local authority is responsible for implementing the Clean Air Act 1993 including designation and supervision of smoke control areas and you can contact them for details of Clean Air Act requirements.

Further information on the requirements of the Clean Air Act can be found here : <https://www.gov.uk/smoke-control-area-rules>

The following list of Farringdon models :

- Farringdon Small 4.9 Kw wood burning stove
- Farringdon 8 Kw Freestanding wood burning stove
- Farringdon Large 12 Kw wood burning stove

are currently exempt or have been recommended as suitable for use in smoke control areas, when burning wood logs and are fitted with a factory set mechanical stop, to prevent air closure beyond a percentage (%) from the nominal burn position.



## 3 Recommended fuels

### 3.1 Wood

As a natural and renewable fuel, wood is the first choice for burning, however burning wood requires a little effort and planning.

Any type of wood is suitable (though hardwood is preferable) provided it is well seasoned and has a moisture content below 20%. This usually implies that the timber has been suitably stored to allow moisture to evaporate for at least 9 months in the case of soft wood, and at least 24 months in the case of hard wood. We recommend that for general burning, wood should be split into logs of no more than 100mm (4 inches) diameter.

If, when burning wood, you see signs of sticky tar inside the appliance or chimney, your wood is 'green' or too wet and requires further seasoning. An electronic moisture meter can be obtained in order to determine the moisture content of your wood fuel.

Wet wood must not be used as this will greatly contribute to the creation of tar and creosote which may, in extreme cases, run down the chimney in liquid form. This will seriously damage both the chimney and the appliance and increase the risk of a chimney fire.

Paper will burn successfully. Burn dry paper only or damage will occur to the flue or chimney with an increased risk of a chimney fire.

## 4 Before using your stove

Arada stoves are designed to be operated with the fire door(s) closed at all times, apart from refuelling (when alight) or cleaning (when cold).

Never leave the appliance unattended for an extended length of time with the door(s) open.

Prior to lighting the stove for the first time, please check with the installer that:

- Installation and all building work is complete. (Refer to the installation guide.)
- The chimney is sound, has been swept and is free from obstruction.
- Building Regulations and any local by-laws have been followed during installation.
- All firebox liner panels and throat plate are in place.
- The chimney draw has been checked and is within specification (between 0.1mb to 0.2mb, or 10-20 pascals). This ensures your stove will operate predictably and efficiently.
- Carbon Monoxide detector is correctly installed in the same room as the appliance.
- Suitable provision for combustion and ventilation air, depending upon building regulations have been undertaken by the installation fitter.
- Consideration must be given for the need for extra ventilation if another heating source needing air is to be operated simultaneously. If an extraction fan is proposed to be fitted to a connecting area of the house, after the stove has been installed, professional advice should be sought from a qualified engineer.

Ensure that you have read and understood these instructions before lighting the fire.

Our YouTube channel, [www.youtube.com/user/aradastoves](http://www.youtube.com/user/aradastoves) features a collection of videos designed to help you get the best from your Arada stove.

Always wear suitable protective fire gloves when refuelling your stove, such as the Arada hot gloves supplied with your stove. Always keep the hot glove away from naked flames and sparks, when re-fuelling the appliance.

We recommend that you light a small fire for the first few days of use to cure the paint and allow the castings to relax. During this process the paint surface may smoke briefly, and you may smell a slight odour. The vapour is harmless and should not be confused with fume emissions, however, it is advisable to keep the area well ventilated until the vapour disperses.

You may hear your stove produce clicking or ticking noises whilst it heats up or cools down. This is completely normal and is produced by the expansion and contraction of the steel components in your stove when its temperature changes.

## 5 Air inlet controls

### 5.1 Air Inlet

Your stove requires air to function, this enters the appliance via the circular duct at the rear of the stove. During installation, this circular duct can also act as the connection point for the direct air feed / ducting, depending upon the installation requirements.

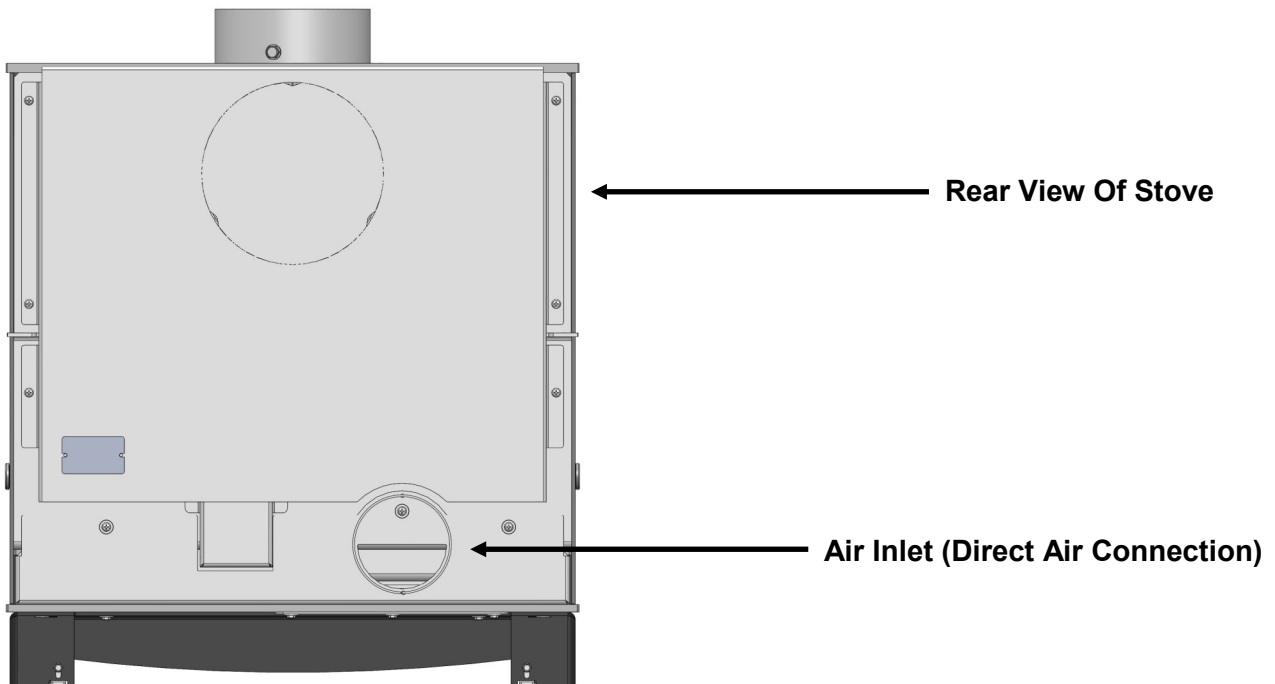

**NOTE : DO NOT COVER OR PARTIALLY OBSTRUCT THE AIR INLET OPENINGS FOR THE APPLIANCE.**

#### 5.1.1 Primary air control location

The primary air control regulates the air entering the fire box chamber, supplying air to the airwash system and upper secondary air tubes.

This control is situated below the fire door on the left hand side, when facing the front of the stove.

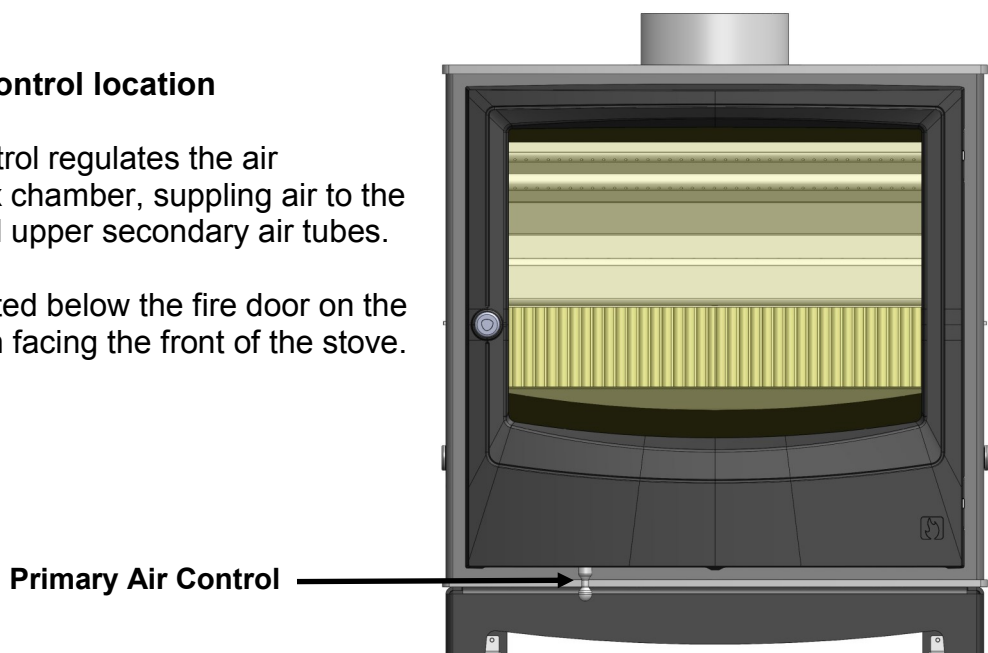

### 5.1.2 Primary air control

The primary air control regulates the air entering the fire box chamber, supplying air to the fuel, together with supplying air in front of the glass viewing panel within the door assembly and upper secondary air tubes.

The control has an internal rotary plate with slots, housed inside the body of the appliance and is located below left hand corner of the fire door assembly. Sliding the control knob to the right, as far as it will go, achieves the fully open position, see figure 1. Sliding it to the left will shut down / reduce the air as shown in figure 2.

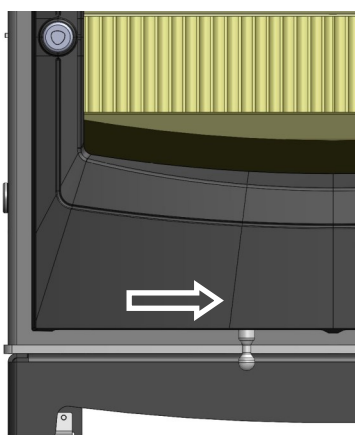

Fig. 1. Fully Open Position

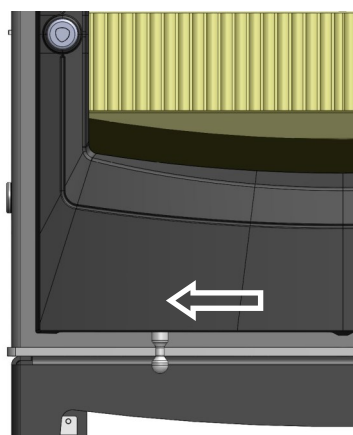

Fig. 2. Fully Closed Position



**NOTE :** All Farringdon models are fitted with a mechanical stop for smoke control areas, please note that the primary air control will not fully close, thus allowing a bleed of air to the fire box to reduce smoke emissions.

### 5.1.3 Tertiary air

All Farringdon models have tertiary air supply that can be seen working during certain conditions during the burning period. The outlet for the tertiary air, is at the rear of the fire box chamber, just below the throat plate through a series of small holes (See page 6).

Tertiary air is employed, to provide additional air to the upper areas of the fire box to promote additional burning of the unburnt combustion gases and thus ensuring a cleaner burn emission.

There is no user adjustment required for the tertiary air as the required air supply is factory set during production process.

## 6 Lighting your stove

### 6.1.1 Smoke control areas

Please check whether your dwelling is located in a smoke control area before installation or use. Please check with your local authority or <https://www.gov.uk/smoke-control-area-rules>.

### 6.1.2 Fuel overloading

The maximum amount of fuel specified in this manual should not be exceeded, overloading can cause excess smoke. Please see technical data section in this manual.

### 6.1.3 Operation with door left open

Operation with the door open can cause excess smoke. The appliance **MUST NOT** be operated with the appliance door left open except as directed in the instructions.

### 6.1.4 Dampers / Air controls left open

Operation with the air controls or appliance dampers open can cause excess smoke. The appliance must not be operated with the air controls, appliance damper or door(s) left open except as directed in these instructions.

## 6.2 Burning wood

When wood is burnt, it is in fact the volatile gases released from the wood, that burn and this requires a good supply of air coming from above the fuel.

For this reason we will use all the air inlets while igniting the stove, but will then reduce this to air coming from the air wash system and over draught. As much as 40% of the heat from burning wood is obtained from secondary combustion and this can be severely hampered by air entering the fire box from below the fuel.

- 1) Set the fire by using scrunched up newspaper and placing a layer of dry kindling wood on top of this. The use of two or three fire lighters may assist in lighting the kindling.
- 2) Fully open the primary air control and light the fire lighters and or paper.
- 3) After the kindling has caught light, you should almost close the fire door leaving it ajar by about 10mm. This will aid flue draw during the initial lighting of the fire.
- 4) The flue temperature and draw should be established after five minutes and the kindling reduced to form an ember bed. Carefully load the stove with well seasoned wood and fully close the fire door.
- 5) After ten minutes, regulate the primary air control to control the burn rate and maintain clear glass, typically by reducing to approximately half open.

### 6.3 Burning solid fuels

All Farringdon stoves are designed to burn wood only— **NO SOLID FUELS ALLOWED.**



**Please do not attempt to burn solid fuels in a dedicated wood burning stove.**

### 6.4 Warning - Fume / Smoke emissions

Properly installed, with a suitable flue or chimney, operated and maintained correctly, this appliance will not emit fumes into the dwelling. Occasional fumes when de-ashing and refuelling may occur. However, persistent fume emission is potentially dangerous and must be investigated by a approved / registered installer.



**STOP USING THE APPLIANCE IF YOU SMELL FUMES OR SEE SMOKE ESCAPING.**

If fume emission does persist, the following immediate actions should be taken:

- Open doors and windows to ventilate room.
- Let the fire die or extinguish and safely dispose of fuel from the appliance.
- Check for flue or chimney blockage, and clean if required.

Seek expert advice from your approved installer.

Do not attempt to re-light the fire until the cause of the fume emission has been identified and corrected.

## 6.5 Refuelling on to a low fire bed

If there is insufficient burning material in the fire bed to light a new fuel charge, excessive smoke emission can occur. Refuelling must be carried out onto a sufficient quantity of glowing embers and ash that the new fuel charge will ignite in a reasonable period. If there are too few embers in the fire bed, add suitable kindling for ignition to prevent excessive smoke.

**Important notes on usage, to meet the requirements of Smoke Control exemption -**

- **Always recharge onto hot embers.**
- **After re-charging, leave the door ajar for approximately 3 minutes in the case of the Farringdon *Small / Medium* appliance and 4 minutes for the *Large* model to establish good combustion.**
- **Do not leave the appliance unattended until flames are well established.**
- **Periodic burning out of the fuel bed at high output to combust any remaining charcoal.**

### NOTE :

The minimum air control setting is governed in manufacture to meet the requirements of Smoke Control exemption and as a result the appliance will **NOT** shut down completely when in the minimum air position setting.

Removal or modification of the factory fitted air control plate (See Fig. 3) is illegal when the appliance is installed in a smoke exemption area and doing so may result in prosecution and fine.

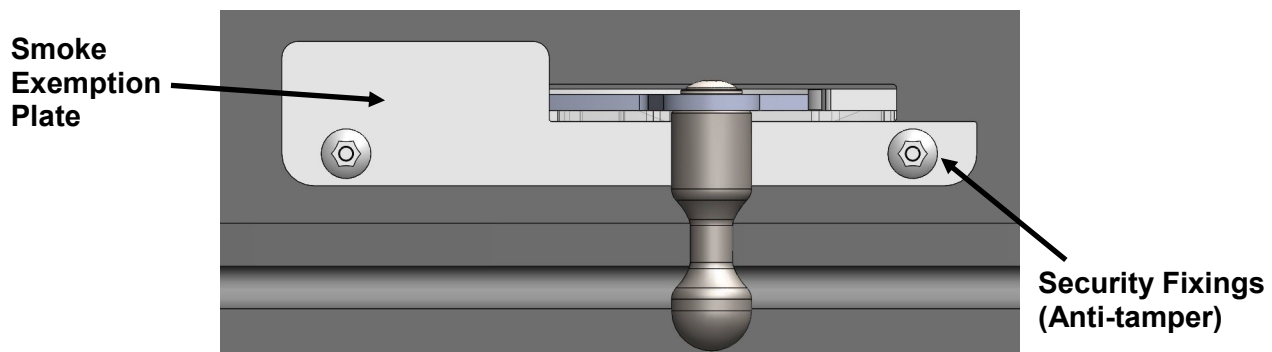

**Fig. 3. Factory Fitted Smoke Exemption Plate**



NOTE : It is recommended that wood logs are placed centrally against the rear liners, within the firebox to ensure the most efficient use of the fuel.

## 6.6 Typical wood burn for nominal output

To perform the most efficient burn at the nominal rated output please consult the specification table at the rear of this manual. Please note, many factors can effect the nominal output, so the stated weights of fuel (Seasoned Hard Wood) are a guide, which is a representation to laboratory burn conditions.

## 7 Further information for all stove owners

### 7.1 Door glass

The door glass should remain clear during normal burning. However under certain conditions, such as burning at a low or slow rate, using damp wood or overnight burning, the glass may become somewhat blackened. To remedy this, operate the appliance at a fast rate. Alternatively when the stove is cold, open the door and clean the inside face of the glass with a damp cloth or with glass cleaner ([www.aradastovesandspares.com](http://www.aradastovesandspares.com) or Arada dealers).

### 7.2 Reduced burning (Slow Combustion)

When wood is burnt slowly in a closed appliance (eg: air controls at the minimum setting), it produces moisture and tar, which will create condensation and deposits in the chimney. This effect can be minimised by burning hard for a short period, fifteen to twenty minutes twice a day.

To avoid chimney problems your appliance should not be burnt at a reduced burn rate without a period of fast burning. Fast burning is when the stove is burnt with a 'lively flame' and a higher temperature. We strongly advise against stoking the fire with wood and reducing the air inlets before leaving the stove to extinguish (perhaps when retiring to bed) as this can lead to a cooling of the stove and flue also resulting in incomplete combustion, sooty deposits and high levels of pollutant gases released into the environment.

### 7.3 Over firing

**DO NOT** over fire your appliance. Firing the stove at maximum for prolonged periods may result in over-firing. If the chimney connector or casing glows red the appliance is being over-fired and this may result in a chimney fire. Other signs include warping and a red-oxide colouring will demonstrate the over- heating of internal parts; body paint which has turned dusty white is also indicative of such use.

### 7.4 Chimney fires

Used in the correct manner, with the correct fuel and regular maintenance a chimney fire should never occur, however in the even of a chimney fire, the following procedure should be actioned without delay:

- **Call the fire service—DIAL 999**
- **Immediately close all of the air inlet supplies on the appliance, to reduce the air supply to the stove.**
- **Move items of furniture and combustibles away from the surrounding area of the stove, to reduce the risk of fire and allow access for the fire service.**
- **Ensure access to the loft space is available.**
- **Evacuate the property.**



## 7.5 Ash removal

The ash pan should be emptied when the level of ash reaches the top of the ash pan. On no account should the ash be allowed to build up to touch the underside of the grate bars, as this will greatly reduce the life span of the grate.

**To remove the ash pan ALWAYS USE the supplied hot gloves -**

- Open the door of the stove, pausing briefly when ajar so as to allow the fire to adjust to the increased air supply.
- Locate the central handle on the ash pan with one hand.
- Carefully withdraw the ash pan from the ash pit chamber.
- When the second lever handle is exposed hold this with the remaining hand, thus acting as shovel.
- Empty the ash into a suitable metal container. Replace the ash pan into the stove, reversing the above procedure and close the fire door.

**Warning:** The ash can be very hot. Care must be taken not to burn hands or household objects with falling embers—**ALWAYS USE THE HOT GLOVES SUPPLIED.**

Empty only into a metal container. Even if the ash appears cold, red-hot embers may be concealed and could easily start a fire or cause an injury.

## 7.6 Periods of non-use (summer months)

Please ensure that your stove is left clean and moving components are well lubricated with a water repelling corrosion inhibitor for the summer months (during periods of prolonged non-use). If possible store the throat plate outside of the stove. Check all moveable components at regular intervals, to ensure they are moving freely. Allow air movement through the stove by opening the primary air inlet control(s) to about half way, open or leave the door ajar. This will allow a free flow of air through the appliance thus preventing moisture and condensation forming inside the stove and chimney. This preventative maintenance will ensure your stove stays in the best condition for the coming winter months.

## 7.7 Classification

All Farrington stoves are classed as intermittent operation . There by meaning, to give nominal rated output, you will have to refuel a minimum of 45min for wood or 1hr for solid fuel, as stated in EN 13240:2011 +A2:2004, however, all Farrington stoves exceed the minimum refuelling time and the nominal outputs are quoted at 1hr burn rates for wood.

## 7.8 Adverse Weather Conditions

If due to adverse weather conditions your stove does not operate correctly and causes the stove to emit smoke, do not treat it as a nuisance, this smoke will indicate that carbon monoxide is being emitted into the room. Extinguish the stove by reducing the firing rate, open windows and allow the stove's fuel to burn out before closing the windows. The probable cause is insufficient draw, check flue ways and have the chimney tested for flue pressure.

## 7.9 Replacement parts

Genuine replacement spare parts can be obtained from [www.aradastovesandspares.com](http://www.aradastovesandspares.com) or your Arada dealer.

You can find a complete list of spares and consumables such as liners, grate bars and throat plates as well as items to enhance its visual appearance and efficiency such as stove paint and rope kits.

It is worth noting that the fitting of non-official Arada parts to your stove will invalidate its guarantee.

## 8 Further information

### 8.1 *Flexifuel* grate bars

The Patented 'Flexifuel' grate system in your Arada stove comprises of a series of reciprocating cast iron bars seated on a pivoted comb. These should come pre-assembled in your new stove.

All bars in the grate are identical, but every other bar is turned 180 degrees, with the ends of the bars marked "H" sitting on the high sections of the comb, and the ends marked "L" sitting on the low sections.

After extended use it may be necessary to replace some of the grate bars.

### 8.2 Fire door handle / riddle handle

All Farringdon stoves are supplied with a detachable handle with a tear drop shaped boss that can be inserted for use; to open / closed the fire door and to de-ash the grate riddle socket (located on each forward sides of the stove).

It is recommended that the handle is removed from the appliance when in use, to avoid heat absorption to the handle. However, it is advised to keep this handle in the vicinity of the stove at all times.



**ALLWAYS USE THE HOT GLOVES WHEN USING THE FIRE DOOR / RIDDLE HANDLE— RISK OF PERSONAL INJURY MAY OCCUR.**

### 8.3 De-ashing the firebox

With the main fire door closed, insert the removable handle into either the left or right grate riddle sockets. Move the handle up and down, repeatedly, until ember / ash bed is reduced. Follow the procedure on ash removal when complete.

## 9 How heat is delivered by your stove

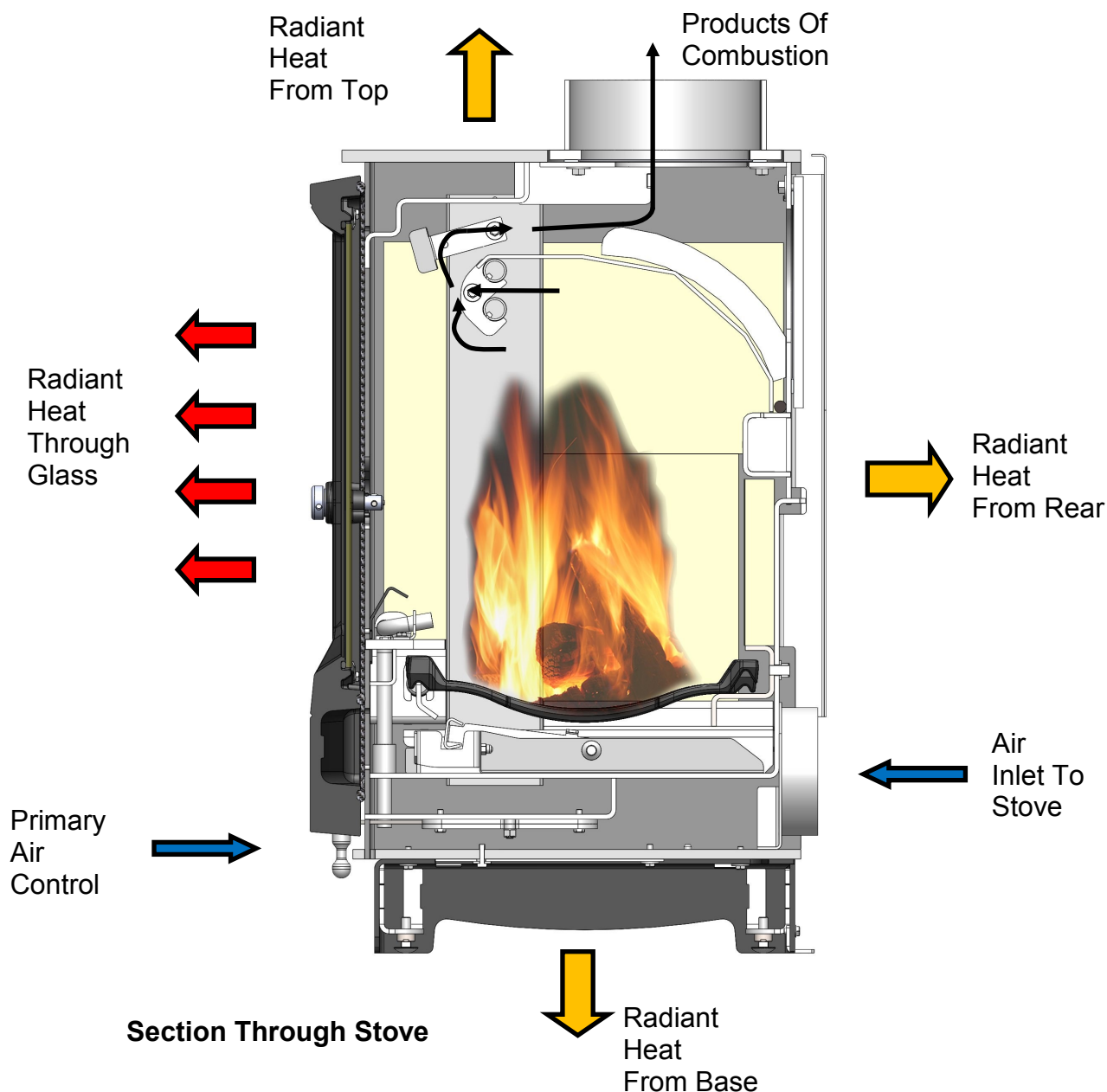

### 9.1 Radiant heat

All Arada stoves radiate heat into the room. The radiated heat is most intense at the front of the stove, especially through the door glass and less intense the further you move away from the stove.

This radiated heat is delivered as infrared rays which heat the objects they strike. It is then these objects (such as the chimney breast, hearth etc.) which heat the surrounding air.

## 10 Care for your Arada stove

The need for regular maintenance on your stove will ensure, safe and efficient use of your appliance. The following item listing should be checked and inspected by a competent person or engineer on a regular basis.



**PLEASE ENSURE THAT THE STOVE IS UNLIT AND COLD, BEFORE ATTEMPTING TO INSPECT THE BELOW ITEMS -**

### 10.1 Adjusting the door hinges

Once the appliance has been under fire for a period of time the fire door may appear to have moved out of alignment with relation to the door aperture or catch. This is quite normal and due to the settling of the casting.

**If the fire door needs to be raised, please follow the instructions below:**

Open the fire door so that it is at right angles to the front of the stove and support the door assembly on blocks of wood etc.

Remove the 2 no. screws and top hinge retaining plate, (please note it may be necessary to loosen the 2 no. screws in the lower hinge retaining—DO NOT REMOVE) carefully move the door assembly away from top hinge pin.

Drop one washer over the top hinge pin. Align the door assembly onto the hinge and re-fit the hinge retainer. Check & repeat again if necessary.

### 10.2 Liners / firebricks

The stoves liners (also known as firebricks) may become cracked after long periods of heavy use or after being knocked by the loading of fuel or a poorly aimed fire poker. If the liners are still staying in situ and are able to support the throat plate correctly there is no need to replace them. Cracked liners will not in themselves effect the performance of the stove.

### 10.3 Throat plate & Insulation blanket

An insulation blanket is fitted above the stoves throat plate, the job of this blanket is to reduce the heat from being directed up the flue and thus wasting energy. The blanket can be removed by gently sliding out of place from the top of the throat plate. Over a period of time the blanket will become saturated with soot and products of combustion, it will need to be replaced.

The throat plate should be removed from the stove, by lifting the front edge away from the upper secondary tube and withdrawing the two tabs from the location slots within the tertiary air outlet. Rotate the two tabs, so that these are facing you, then lower the part on to the grate bars. If the throat plate needs to be removed from the fire box it can be manipulated through the door opening. Any accumulated deposits should be cleaned off, this is best done with a brush. Whilst doing so, inspect the throat plate for any damage. Replacement throat plate and insulation blankets can be sourced from your dealer or [www.aradastovesandspares.com](http://www.aradastovesandspares.com).

#### **10.4 Fire door seal**

The rope seal around the edges of the main fire door should also be checked. Look for signs of fraying, peeling away or the ends not meeting. If the rope is unable to create a good seal with the stove body it should be replaced. A poor seal will decrease your ability to control the burn rate and its efficiency whilst leading to an increase in heat lost through the flue.

#### **10.5 Cracked glass**

It is not recommended to operate the stove with cracked glass; this can lead to over firing due to air leaking into the firebox and it may fail completely leading to personal injury or a fire.

You should discontinue use of your stove until it has been repaired. You can source replacement glass kits from [www.aradastovesandspares.com](http://www.aradastovesandspares.com) or your Arada dealer.

#### **10.6 Chimney / Flue Sweeping**

Sweeping should be carried out with an appropriate sized bristle brush and rods to suit chimney size and type. As with all appliances regular sweeping of the flue / chimney is essential to avoid dangers of blockage and the escape of poisonous fumes. Access for cleaning should also be incorporated in the chimney (eg: soot door or access through the register plate etc).

It is important that the flue connections, flue pipe and chimney be cleaned prior to lighting after a prolonged period of non use.

## 11 Further resources / reading

Once again we would like to thank you for buying your Arada stove.

### 11.1 Information

We appreciate that we have given you a lot of information to read, but we hope it has been clear and helpful and that you are now able to enjoy the full benefits of your stove.

However if you have any queries, doubts or would like further advice please do not hesitate to speak to your Arada dealer or call us. You will find our contact details below, as well as a list of resources where you can discover more information about your stove and associated articles.

- Arada Technical Support  
01297 35998  
technical@aradastoves.com

- Arada Stoves Support Site  
[www.aradastoves.com/support](http://www.aradastoves.com/support)

- Competent Person Schemes  
<https://www.gov.uk/guidance/competent-person-scheme-current-schemes-and-how-schemes-are-authorised>

- Document J Building Regulations (Combustion Appliances)  
[www.planningportal.gov.uk/](http://www.planningportal.gov.uk/)

- The National Association of Chimney Sweeps (NACS)  
[www.nacs.org.uk/](http://www.nacs.org.uk/)

### 11.2 Specifications

All Arada Farringdon stoves are manufactured and independently tested to EN standard 13240 and are CE marked. Within the above EN standard, material specifications and criteria are defined.

## 12 Guarantee

When you buy an Arada stove, you are not only buying a first class appliance, you are receiving a commitment from us to look after you and your appliance.

### 12.1 Guarantee

If any part of the main body of the stove fails due to a manufacturing or material defect during the guarantee period that applies in respect of the relevant stove (as set out below), Arada will, at its sole discretion, repair or replace your Arada stove, for no charge.

For the purposes of this guarantee, a material or manufacturing defect includes the splitting or cracking of the main body (defined as the steel outer casing and items fixed immovably to the casing).

Damage caused by over-firing or over-heating is not covered (as described in the operation manual). Warping and a red-oxide colouring will demonstrate the over-heating of internal parts; body paint which has turned dusty white is also indicative of such use.

The following guarantee periods shall apply in respect of the following Arada stoves:

Arada stoves come with a lifetime guarantee to the main body.

The external paint finish carry a one-year guarantee only.

This guarantee is subject to the Terms and Conditions set out below.

### 12.2 Terms and Conditions

The following terms and conditions must be satisfied in order for your stove to be covered by the guarantee set out above:

1. Your stove must have been purchased from an officially approved Arada dealer.
2. You must be the original purchaser of the stove in order to make a claim. This guarantee is not valid in relation to any claims made by someone who did not originally purchase the stove from Arada or an approved Arada dealer.
3. Any claim under this guarantee must be made through the approved Arada dealer where the stove was purchased and accompanied by proof of purchase (e.g. a valid receipt). Stoves not purchased from an approved Arada dealer will not be covered by this guarantee.
4. Your stove must be installed in the UK for this guarantee to be valid. Stoves installed outside of the UK will not be covered by this guarantee.

5. Your stove must have been installed by a suitably qualified person and in accordance with the manufacturer's installation instructions. Stoves not installed by a suitably qualified person or not installed in accordance with the manufacturer's installation instructions will not be covered by this guarantee.

6. Any claims under this guarantee shall not be valid where the installation of the stove does not conform to all required building regulations and other legislation in force at the time of purchase and where flue draw readings have not been made to confirm a suitability of the flue. The manufacturer's decision as to whether this condition has been satisfied shall be final.

7. The guarantee does not cover damage caused to the stove through careless handling or misuse or neglect of the appliance (misuse and neglect being not following the manufacturer's instructions and user guides in relation to the stoves, including the use of non-recommended fuels).

8. The following consumable service items are not covered by this guarantee:

- Firebox linings
- Grate bars
- Fuel retainer
- Throat plate
- Gaskets
- Door glass
- Seals

9. The guarantee does not cover damage caused by storing or using the stove in a damp environment, defects or faults caused by local conditions such as draught problems and chimney defects or corrosion caused by condensation, damp or water ingress into the flue, chimney or the surrounding of the stove.

10. The guarantee is only valid if the stove is serviced and checked annually by a suitably qualified heating engineer, with documentation to be retained and produced in the event of a claim being made.

11. The guarantee is only valid where any spare parts used are supplied by Arada or an approved Arada dealer. The use of spares other than those supplied by Arada Limited shall invalidate the guarantee. Parts can be purchased through an approved dealer or directly from Arada, online at [www.aradastoveandspares.com](http://www.aradastoveandspares.com).

12. The guarantee is not valid where any repairs or modifications have been made to the stove which have been carried out by anyone other than Arada or its authorised representatives or approved dealers.

13. All guarantee periods commence on the date of purchase and are non-transferable and solely for the benefit of the original purchaser of the stove.



### **12.3 General**

Our guarantee is offered as an addition to your statutory rights and will not effect your statutory rights. You can obtain information about your legal rights from trading standards office's or a citizens' advice bureau.

If you believe your appliance is not working correctly or it has broken down, in the first instance please contact your local retailer or installer for assistance.

This guarantee is applicable in the UK only and operates exclusively in accordance with the laws of England and Wales.

### 13 Technical specification

TECHNICAL DATA	Farringdon Small	Farringdon Medium	Farringdon Large
Nominal Heat Output (Kw)	4.9	8.0	12.0
Efficiency Nett (%)	78.3	77.7	76.3
Mean Flue Gas Temperature (°C)	273	343	357
Mean CO Emission @ 13% O2 (%)	0.19	0.15	0.24
Flue Mass Gas Flow (g/s)	4.4	5.6	8.4
Minimum Distance to Combustible materials (mm)	460 (Rear) 400 (Side)	400 (Rear) 450 (Side)	350 (Rear) 400 (Side)
Height (mm)	638	666	666
Width (mm) Across Canopy	495	533	615
Depth (mm) (Inc. Handle Boss)	355	355	426
Height To Centre Of Rear Flue (mm)	520	548	548
Depth From Back To Flue Centre (mm)	112	112	112
Flue Diameter (mm)	127 (5")	127 (5")	152 (6")
Weight Packed (Kg)	106	122	140
Weight Nett (Kg)	101	117	134
Ideal Log Length & Diameter (mm)	360 / 100	420 / 125	500 / 150
Maximum Hearth Temperature (°C)	46	62.2	40
Typical Fuel Load To Achieve Nominal Rated Output Per Hour (Kwh/Kg) (Seasoned hardwood)	1.48	2.37	3.62

## 14 Notes -



arada  
— stoves —

**All Arada Stoves are manufactured in the UK**

---

**Arada Ltd**

Weycroft Avenue - Axminster - Devon  
EX13 5HU  
United Kingdom

[www.aradastoves.com](http://www.aradastoves.com)

T: +44 (0)1297 35700

[info@aradastoves.com](mailto:info@aradastoves.com)