

ARADA
— DEVON —

Wet stove installation guide



BK555 REV 13

EN 13240:2001 +A2:2004

Issue Date: 26/01/2023



Wet stove installation guide

Please carefully read through the entirety of this installation guide before commencing installation. Should you have any questions about our stoves that are not covered in this manual, please contact the Arada retailer in your area, or call our technical support department on +44 (0)1297 632052.

Arada has a policy of continuous product development and therefore we reserve the right to amend specifications without prior notice.

Please check with your retailer or dealer if you are unsure about any aspect of your stove, its installation or correct use.

Contents

	Page No.		Page No.
<u>INTRODUCTION</u>		<u>CONNECTING THE BOILER TO YOUR</u>	
Warnings	4	<u>HEATING CIRCUIT</u>	
Health and Safety.....	4	Safety cooling loop (for Stratford dedicated wood boilers).....	10
<u>INSTALLATION REQUIREMENTS</u>		Integral boilers.....	10
Hearths and Recesses	5	Water Connections	11
Combustible Materials.....	5	Safety Vent Circuit	11
Air for Combustion.....	5–6	Thermostat and damper pressure checks	12
<u>FLUES AND CHIMNEYS</u>	6–7	Removing the thermostat	12
<u>INSTALLING THE STOVE</u>		Calibration	12
Removing the door	8	<u>MAINTENANCE</u>	
Assembling the grate bars	8	Removal of ash around the under grate air inlet.....	13
Fitting the spigot outlet to the stove	8	Removal of ash around the thermostat assembly.....	13
Connecting the spigot outlet to the flue system	9	<u>FINAL CHECK LIST AND COMMISSIONING</u>	
Fire bed surrounds	9	<u>THE STOVE</u>	14
Flue Exhaust Diversion System (FEDS)	9	<u>APPENDIX</u>	
Sealing the back and base of inset stoves to a fire surround	9	Example diagrams of central heating configurations.....	15
Adjusting the self-levelling feet (Free Standing Models)	9		

Warnings

It is a legal requirement that the installation of all new or replacement, wood or solid fuel heating appliances obtain Building Control approval from your local authority. This can be done by using a qualified heating engineer, affiliated to a government approved Competent Persons Scheme such as those listed on www.gov.uk/building-regulations-competent-person-schemes

You can also consult your local buildings inspector / controller.

All local regulations, including those referring to National and European standards, need to be complied with when installing the appliance.

Refer to the current issue of BS 8303 code of practice for the installation of domestic heating appliances burning solid mineral fuel.

This stove should not be installed into a chimney that serves any other heating appliance.

Any manufacturer's instructions must not be taken as overriding statutory requirements.

Arada Ltd will not be responsible for any consequential or incidental loss or injury however caused.

Any further warnings in this document will be marked out in a box such as this one. Ignoring the warnings could lead to damage/injury to persons and/or property.

Health and safety

Before any installation work is undertaken consideration must be given to the Health and Safety at Work Act 1974. Safe working practices should be followed at all times.

Please consult health and safety guidelines for advice on handling heavy and/or large items.

During installation ensure that adequate precautions are taken to avoid unnecessary risk to yourself or any householder.

The danger from the caustic nature of fire cement, should be avoided by using these accepted methods: Wear gloves when handling fire cement. Wear goggles when chiselling or looking up chimneys.

This stove contains no asbestos. If there is a possibility of disturbing any asbestos in the course of the installation then please seek specialist guidance and use appropriate protective equipment.

Installation requirements

Hearths and Recesses

The stove should be installed on a surface with adequate load bearing capacity. If the existing construction does not meet this prerequisite, suitable measures (e.g. load distributing plate) should be taken to achieve it. Please pay particular attention when examining existing building work for suitability to meet the following requirements.

When installing an inset stove, hearths should have a sufficiently flat surface to allow a good seal to the stove body to be created during its installation.

Stonework, uneven bricks etc., may need further work to ensure that this can be achieved. Any voids behind an inset stove should be filled with vermiculite or similar.

The stove should be installed on a non-combustible surface not less than 12mm thick (conforming to Building Regulations unless otherwise specified) of suitable load bearing capacity and heat resistance. Allowances should be made for the expansion and contraction of any materials which are fitted up to and near the appliance.

If required, the dimensions of any constructional hearth for all stoves should project at least 500mm forward of the front of the appliance and 150mm at the sides. The surface of the hearth should be free of combustible materials. The superimposed hearth for all installations should project at least 225mm forward from the front of the appliance and 150mm either side of the edge of the appliance.

In most buildings with solid concrete or stone floors, the requirement will be met by the floor itself, but mark the hearth to ensure floor coverings are kept well away or use different levels to mark the hearth perimeter.

Please be aware that hot air can cause staining above the fire in a similar fashion to walls above radiators. To help prevent this and cracking we recommend that any plaster above the fire should be fitted with reinforcing expanding mesh for at least 220mm above, and the full width of the fire. You should also use a suitably heat resistant plaster which should be allowed sufficient time to fully dry before using the stove or cracking is likely to occur

Combustible Materials

Please view the product sheet which accompanied your stove for specific minimum distances to combustible measurements.

Ideally, adjacent walls should be of suitable non-combustible construction, preferably brickwork.

In large fireplaces take care that any supporting beam is protected by a 13mm sheet of heat resistant fire board spaced 12mm off the surface with strips of non-combustible material. Make sure that there is a gap between an un-insulated flue system and any combustible material. This gap must be at least 3X the outside diameter of the flue pipe, or 1.5X the flue diameter to non-combustible surfaces. Please consult the flue manufacturers specification for insulated flues.

Air for combustion

All stoves require ventilation to burn safely and correctly. There are a number of requirements that need to be met when installing a stove, for example, allowing for the permeability of the house (air permeability is the general seepage of air into the house via air vents, doors and windows etc.)

Air for combustion (continued)

There must always be a permanent means of providing air for combustion into the room in which the stove is installed. Air starvation will result in poor flue draw and may cause smoke to leak into the room.

For all installations it is recommended that a permanent vent with a total free area of at least 550mm² for every kW above 5kW should be connected directly to the outside air. Installations in properties built after 2008 should have their vent increased by a further 330mm² for each of the first 5kW. Alternatively this air can be supplied through an external wall of an adjacent room, which itself has to be connected to the room the appliance is installed by a permanent vent of the same size.

Note: If the appliance is fitted with a draught stabiliser (or if one is fitted to the flue pipe or chimney in the same room as the appliance) then the permanent air entry opening (or openings) should be increased by 300mm² for each kW of rated output up to 5kW and an additional 850mm² for each kW output over 5kW.

If there is more than one appliance in the property then each appliance must be supplied with adequate combustion air so that all appliances can be lit simultaneously.

The positioning of any air vent must be so that it cannot be liable to blockage or obstruction. Ideally it should also be positioned where it is unlikely to cause a cold draught. It should not be positioned in the fireplace recess.

For more detailed guidelines on required ventilation sizes please refer to the Document J Building Regulations (Combustion Appliances) at the www.planningportal.gov.uk website.

Flues and Chimneys

The stove must be connected to a suitable and efficient flue so that products of combustion (fumes) from the stove are expelled to the outside air. Please remember that chimney draught is dependent on four main factors :

- Flue gas temperature
- Flue height
- Flue size
- Flue terminal

To ensure a good up draught it is important that the flue gases are kept warm and that the flue size suits the stove. The termination of the outlet at the top of the flue also needs to comply with Building Regulations. The minimum effective height of the flue must be at least 4.5 metres from the top of the stove to the top of the flue outlet. When warm the flue draught should be between 0.12 to 0.2mb (12 to 20 Pascals).

The draw of a chimney / flue can vary in different weather conditions and the customer should be made aware of this. Failure to correct an over-drawing flue will invalidate the warranty.

A chimney may comply with regulations but could still be subject to down draught and similar problems. A chimney terminating above the ridge level is generally less likely to suffer such problems.

If a new chimney is being provided it should fully comply with the relevant Building Regulations that specify the requirements for solid fuel burning installations.

Flues and Chimneys (continued)

Suitable types of chimney include the following :

- **Masonry Chimney:** Built with clay or concrete liners, or a chimney block system meeting Building Regulations. These types of chimneys should be installed in accordance with the Building Regulations and BS EN 15287-2:2008.
- **Factory Made Insulated Chimney:** Complying with BS 4543:Part 2 (often called Class 1 prefabricated metal chimney). These types of chimneys should be installed in accordance with Building Regulations and BS EN 15287-2:2008.

Due to the gradual introduction of European Chimney Standards chimneys will be specified according to their performance designation as defined in BS EN 1443 that covers the General Requirements for chimneys. The minimum performance designation required for use with solid fuel burning stoves is T600 N2 S D3.

The flue and chimney installation must be carefully checked by a competent person before fitting the stove to ensure it is suitable and will work safely.

If the chimney is old (i.e: built of brick or stone without a liner) or being opened up for reuse additional checks and smoke testing as described in Appendix E of the Approved Document J 2010 Edition should also be carried out to ensure the flue and chimney are in good operating condition.

Check the existing flue is in good condition with suitable access for collection and removal of debris.

It is also important that suitable flue pipe (recommended at least 600mm in length) complying with the Building Regulations is used to connect the stove to the flue in the chimney. Suitable access should be provided into the flue for regular inspection and sweeping of the flue ways.

The installer should comply with Building Regulations requirements in respect of providing a Notice Plate giving details on the chimney, flue lining, hearth and fireplace installation.

Chimneys should be as straight as possible. Horizontal runs should be avoided except where the rear outlet of the appliance is used, in which case the horizontal section should not exceed 150mm in length. If necessary a combination of 45° and 90° bends can be used as long as the sum of their angles is not greater than 180° in total. i.e four 45° bends, or two 45° and a 90° bend.

If the stove appears to be working hard but produces very little output to the room it is likely that excess draw is present in the chimney, and that heat is being sucked out of the appliance and up the chimney. If this is the case we recommend the fitting of a draught stabiliser in preference to a flue damper, in the interest of safety and efficiency.

Installing the stove

To make the stove easier to manoeuvre (and safer) we recommend you remove the following parts which can then be refitted when the stove is in its final position:

- Grate Bars
- Door (To help prevent the glass from breaking)
- Operating Tool
- Ash pan
- Flue Exhaust (excluding EB25HE models)

Removing the door

Open the door so that it is perpendicular to the stove body and then carefully lift the stove door upwards off of its hinges. To replace the door reverse the instructions above.

Assembling the grate bars

In your stove the grate comprises of a series of cast iron grate bars, seated on a pair of combs. All bars in the grate are identical.

The bars should be seated with every other bar rotated 180 degrees, so the ends marked 'H' and 'L' alternate on each comb. When assembling the grate, fit bars to the low sections of the comb first by seating the ends marked 'L' onto the low part of the comb, whilst the ends marked 'H' should then be seated on the high sections.



Figure 1: Grate Bars shown seated on their comb outside the stove.

Fitting the spigot outlet to the stove

The flue outlet spigot and hot plate (blanking plate) can be found packed inside the appliance and must be fitted during installation.

Smear a very thin layer of fire cement on the mating faces of the flue outlet and the hot plate. Fit the outlet to the appliance in the desired position.

Installing the stove

Connecting the spigot outlet to the flue system

The flue pipe must be fitted inside the outlet spigot as shown in Figure 2. Failure to do so could result in the spillage of condensation running down the flue.

Fire cement should be used to create an airtight seal between the flue and spigot.

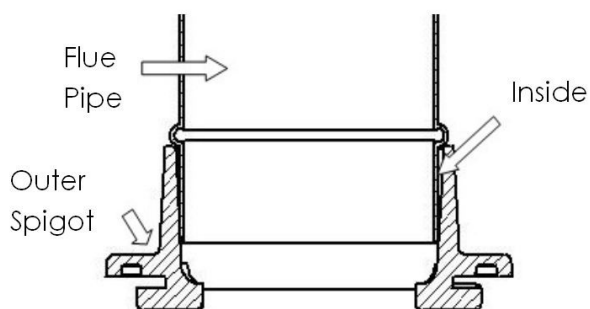

Figure 2: Fitting the flue pipe inside the spigot collar.

Fire bed surrounds

Cast fire bed surrounds are supplied with the boiler stove and should be fitted into the retaining holes in the rear grate bar support.



Flue Exhaust Diversion System (FEDS)

Please note that this does not apply to the EB25HE model which features an alternative system

The inner section of the FEDS is welded in place during manufacturing. The outer FEDS is fitted at the factory but may become dislodged during transit. The rear end of the outer FEDS sits on retaining lugs as illustrated below. If you need to remove the FEDS hold the bottom of it with both hands, palms on the bottom sloping face.

Push up firmly to release the FEDS from the retaining lugs. It may require a swift knock upwards with the palm of your hand to release it.

Sealing the back and base of inset stoves to a fire surround (Inset Models Only)

In order for the stove to operate correctly and at maximum efficiency it is necessary to achieve a good seal between the back face of the stove convector section, the stove back base sections and the decorative fire surround and hearth.

This should be achieved using fire cement. Any void surrounding an inset stove when installed should be filled with fire cement, vermiculite or similar in the interest of safety and efficiency.

Adjusting the self-levelling feet (Free Standing Models Only)

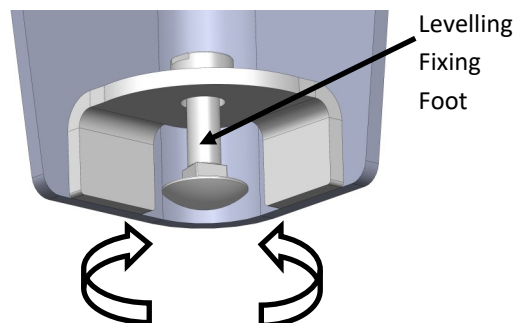

All free standing boiler models are factory fitted with self levelling feet allowing each corner to be independently adjusted, the procedure is as follows:

- Position the stove on the hearth into its final resting place.
- Using a 8mm open spanner, unscrew the levelling foot until this touches the hearth.
- Repeat for the remaining other corners.
- Using a spirit level adjust until the stove canopy is horizontal side to side and front to back.

Connecting the boiler to your heating circuit

Connecting the boiler to your heating circuit

Safety cooling loop (for Stratford dedicated wood boilers)

Your stove features three extra connections as shown in Figure 3. These should be used if you choose to configure your stove installation to work with a cooling loop.

Please seek specialist advice when using these connections. A suggested configuration is shown in Figure 4 .



Figure 3: Cooling loop outlets.

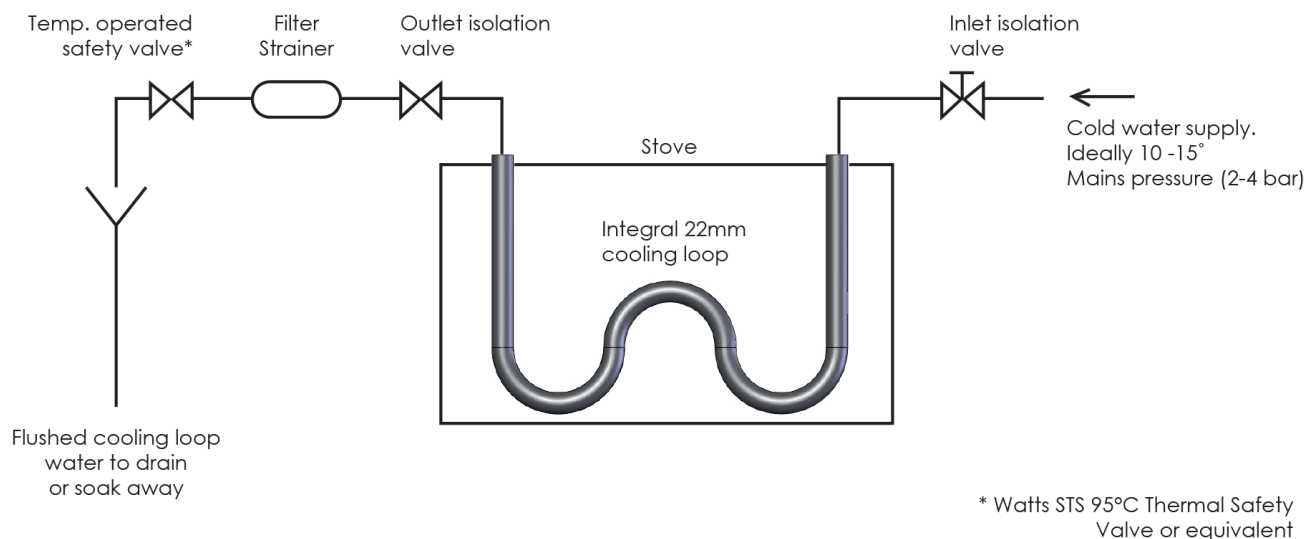

Figure 4: Cooling loop connections.

Integral boilers

All Arada Boiler Stoves must be installed in an indirect vented (also known as open vented) central heating system

Integral boilers should only be connected with the flow and return connections of any circuit on opposite sides of the appliance (cross flowed) and to an indirect hot water tank / system with Fernox or other similar corrosion inhibitor to prevent both corrosion and the formation of limescale.

Connecting pipes should be screwed to a maximum depth of 19mm for the face of the tapping boss (1" BSP, parallel).

Remember to incorporate a drainage plug / tap at the lowest point of the circuit to facilitate draining and flushing.

If a pipe-stat is not fitted to control the radiator circulation pump then cold water corrosion may occur.

Connecting the boiler to your heating circuit

Water connections

To connect the indirect hot water cylinder to the stove use 28mm copper pipes. Ensure that the pipes rise continuously to the cylinder.

Ensure that runs are not too long (i.e. 6 metre maximum each for flow and return). Install the cylinder above the level of the fire and as close to it as possible. Within reason the higher the cylinder the faster the circulation. Ensure no valves are present in the pipes.

In addition to providing hot water the primary circuit is essential in providing a 'heat leak' radiator to absorb excessive heat produced in the event of a circulating pump shutting down.

Heat is produced in varying quantities while the stove is alight and care must be taken to ensure that effective circulation can occur around the primary circuit to carry the heat away thus preventing boiling. The heat output of any radiator installed as a 'heat leak' should not be less than 10 percent of the rated output of the appliance to which it is connected. It should not be fitted with a control valve as it should never be turned off or down. The hot water cylinder must be indirect with a minimum capacity of 110 litres conforming to BS 1566 part 1.

A radiator of approximately 2m² surface area should be connected to the primary circuit.

Safety Vent Circuit

This circuit (shown in Figure 5) consists of a cold feed pipe, a separate expansion pipe and expansion tank. The possibility that water in the stove boiler may boil can never be completely ruled out, and it is therefore vital to ensure that cold water can be provided to the boiler and steam vented from it at all times. The use of an expansion tank is important. This should have a

capacity of at least 7 percent of the systems total water capacity. The cold water feed pipe should be at least 22mm in diameter.

There must not be any shut-off valves in the circuit. Pipes should be run so as to avoid air locks. A safety valve should be fitted into the expansion pipe close to the boiler. The expansion pipe should not be branched off from the cold water feed pipe to ensure that it cannot be blocked by any sediment matter originating from the expansion tank.

It is often possible and good practice to utilise the primary flow and return as part of the safety circuit. The ball valve and overflow pipe (28mm diameter) from the expansion tank should be copper. All pipes in unheated spaces should be lagged.

Various examples can be seen in the appendix

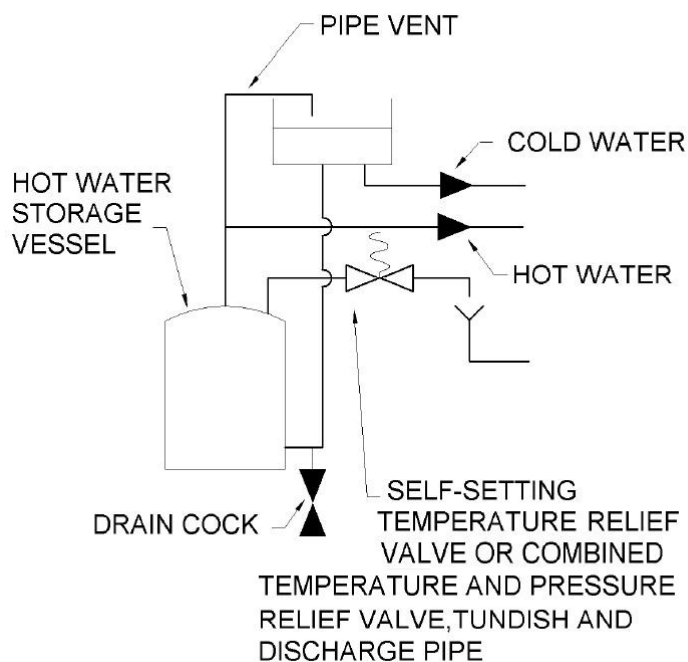

Figure 5: Safety Vent Circuit.

With solid fuel appliances, it is not practical to provide a sufficiently rapid reaction for shutting down the fuel in the event of a sudden rise in water temperature. A temperature valve, or preferably, a combined temperature and pressure relief valve should be installed to operate in the event of high water temperature occurring.

Connecting the boiler to your heating circuit

Thermostat and damper pressure checks

The thermostat has been fitted and set correctly during the manufacture. However it is advisable to check the cold setting prior to lighting the fire for the first time.

With the control knob turned fully clockwise (past No.5) the circular damper plate should have a gap of approximately 29mm between the damper edge and the stove inner body face when measured at the furthest point from the control knob and in line with the actuation shaft. Take care to measure this gap parallel to the actuation arm centre line.

If this is not the case then please follow the steps below to correct it.

To remove the thermostat

1. Pull the thermostat knob off of the shaft.
2. Remove the access cover plate using a No.2 Pozzi screw driver and then remove the M5 screw.
3. Remove the two M5 screws securing the thermostat to the stove body.
4. The thermostat should now be free and you will be able to carefully remove it from the stove body.
5. On the rear of the stove remove the thermostat sensor from its pocket and push this carefully through the hole in corner cut-out of the stove. (Take care not to kink the copper tubing.)

Calibrating

With the thermostat removed, replace the control knob. Rotate the control knob fully clockwise (as viewed with the damper shaft to your left) until you reach the end of possible travel.

Place the thermostat on a flat surface with the base of the mechanism body on a small piece of 8mm thick MDF or similar wood.

Now measure (as shown in Figure 6) the high end of the damper plate between the bench and the top edge of the damper, (the edge furthest from the control knob). This should be 29mm +/- 1mm, if not adjust as follows:

- Slacken off the locking nut against the damper either in or out as required.
- Check the distance at the high end of the damper plate again.
- Once set correctly re-lock the locking nut.
- Check the distance is still correct.

Once the correct distance is achieved please refit the damper flap and thermostat by following the reverse of section 'To remove the thermostat' and check once again that the correct distance is maintained.

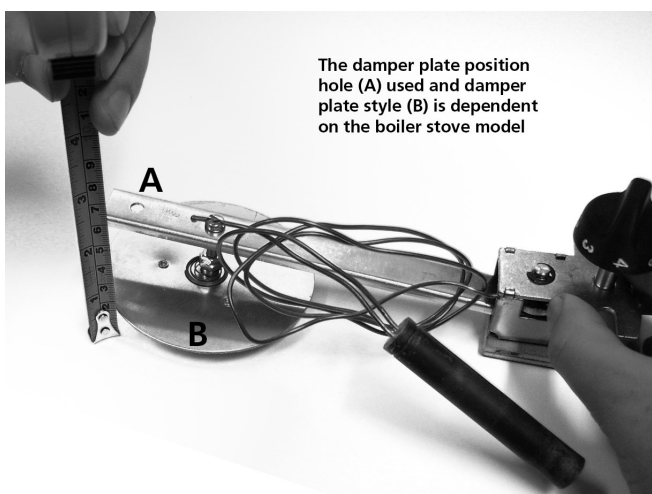

Figure 6: Checking damper flap distance.

Maintenance

Removal of ash around the under grate air inlet

Regular checking and removal of ash from around the under grate air inlet area, is necessary to ensure correct efficient burning and operation of the appliance.

Regular emptying of the ash pan will ensure prolonged build up of under grate ash and debris from the combustion chamber, however it may be necessary to remove the ash that has spilled into the air slot (Fig. 7.), the procedure for this removal is:

- Make sure the stove is unlit and cold.
- Open the fire door and remove the ash pan.
- Clean the under grate area carefully with a vacuum cleaner.
- If you have an EB25HE remove the ash pan location plate (ignore this step for all other models).
- At the rear of the ash pan chamber, locate and remove the air inlet cover, fixing screw.

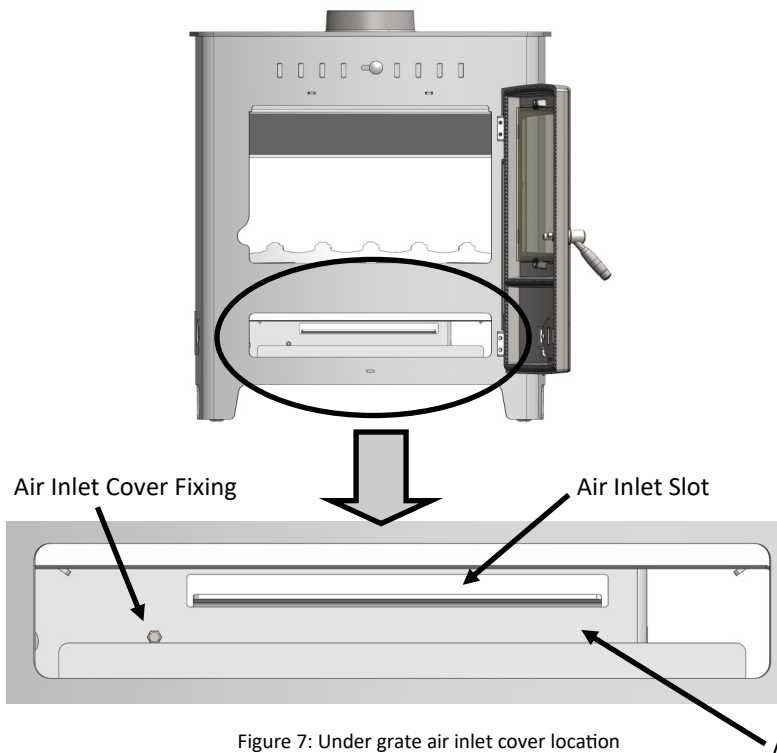

- Remove the air inlet cover and vacuum away the ash and debris.
- Reverse procedure for re-fitting.

Removal of ash around the thermostat assembly

Regular inspection to the thermostat assembly located on the left hand side of the appliance (Fig.8.):

- Make sure the stove is unlit and cold.
- On the left hand side of the stove, remove the fixing securing the thermostat access door.
- Clean the aperture area carefully with a vacuum cleaner.
- Take care not to damage the thermostat assembly.
- Replace the cover and affix screw.

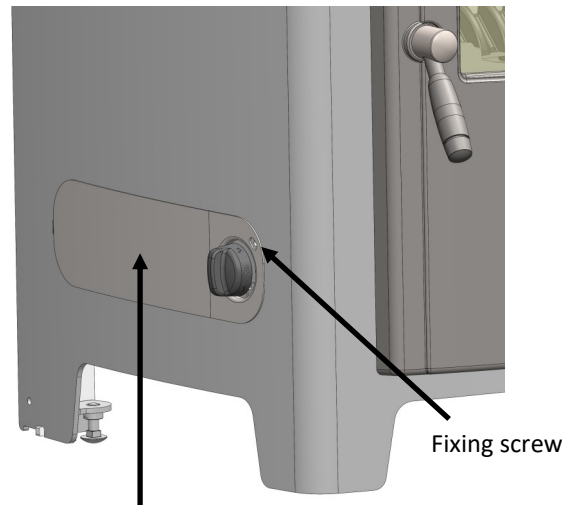

Final check list and commission the stove

Before handing over the installation to the customer it is a requirement under Document J (of the Building Regulations for England and Wales) that the appliance is lit and the functioning of the chimney system is checked for satisfactory operation. The functioning of the hot water and heating system should also be fully checked.

Please record the checks in the table below.

Operate the heating system and set the pump head.	
Balance the radiators.	
Re-vent and ensure there are no air locks.	
Check all joints and seals.	
Clean the outside of the appliance to prevent any stains becoming burnt on.	
Check the flue draught which should read 1.2 - 2mm, or 0.12 - 0.2 mbar.	
For a registered Competent Persons Scheme, (such as those referred to at www.gov.uk/building-regulations-competent-person-schemes), please complete a Certificate of Compliance, which is used for checking and reporting the installation as imposed by the Government.	
Explain the controls and operation of the appliance to the customer.	
Ensure a Carbon Monoxide alarm is fitted. This must be between 1m to 3m of the appliance, and approximately 150mm below the ceiling level.	
A fireguard conforming to BS 8423:2010 +A1:2016 should be used in the presence of children and old or infirm people.	
Explain to the customer, that when lighting a boiler stove, condensation may form on cold parts of the stove and drip off of it during ignition. This is normal and not indication of a leak.	

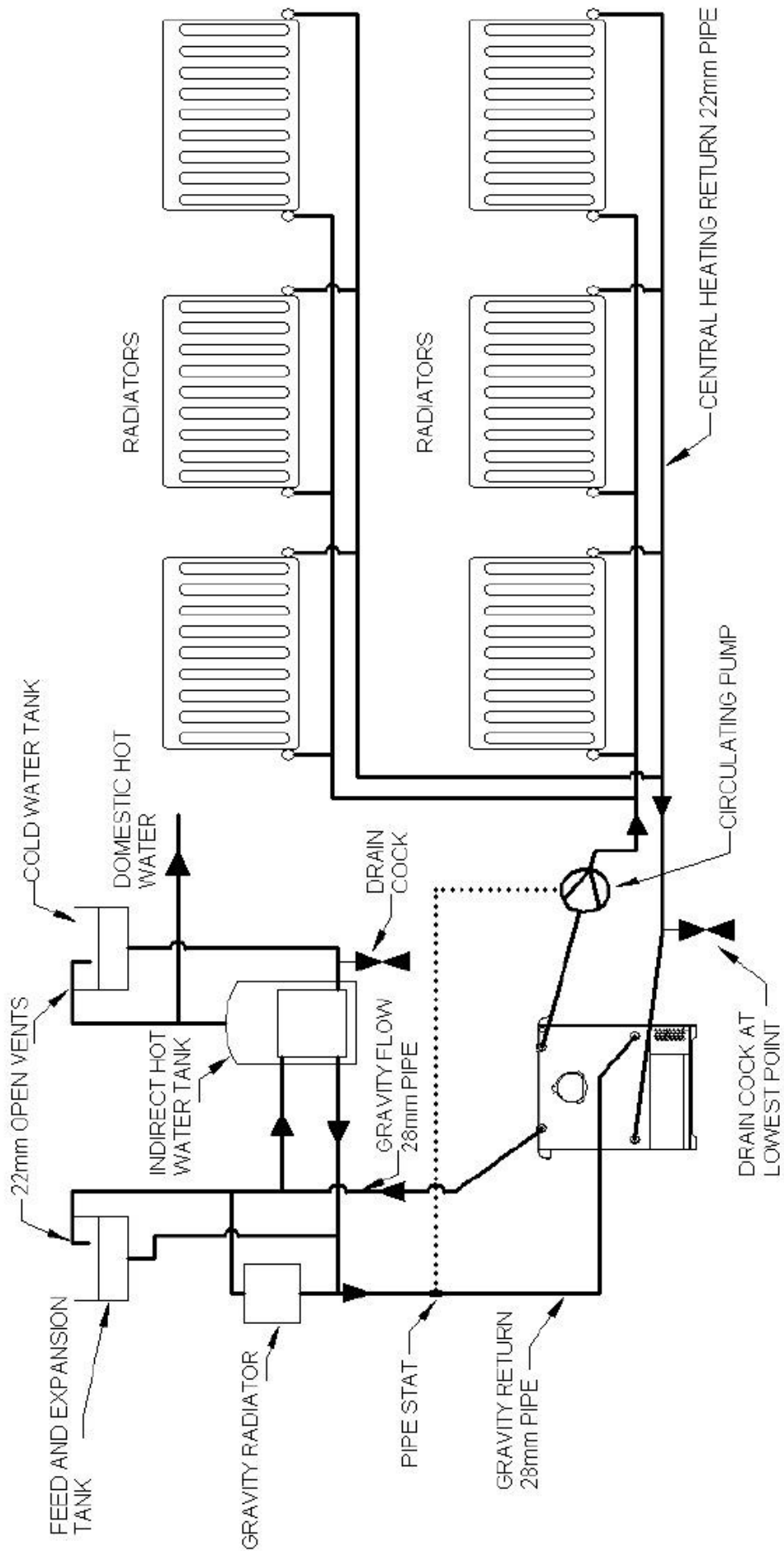

Figure 8: Central heating and domestic hot water system using four boiler tapings.

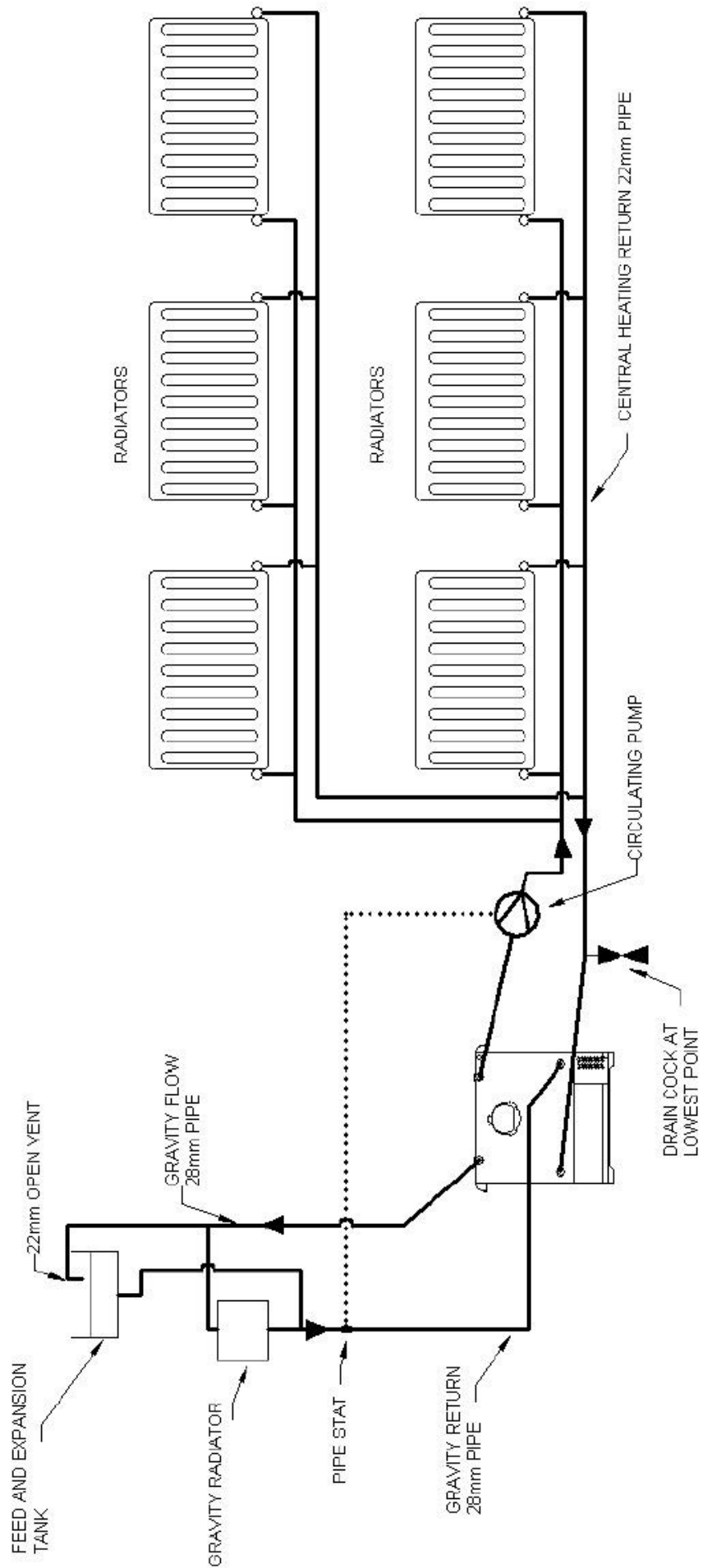

Figure 9: Central heating without domestic hot water system using four boiler tapings.

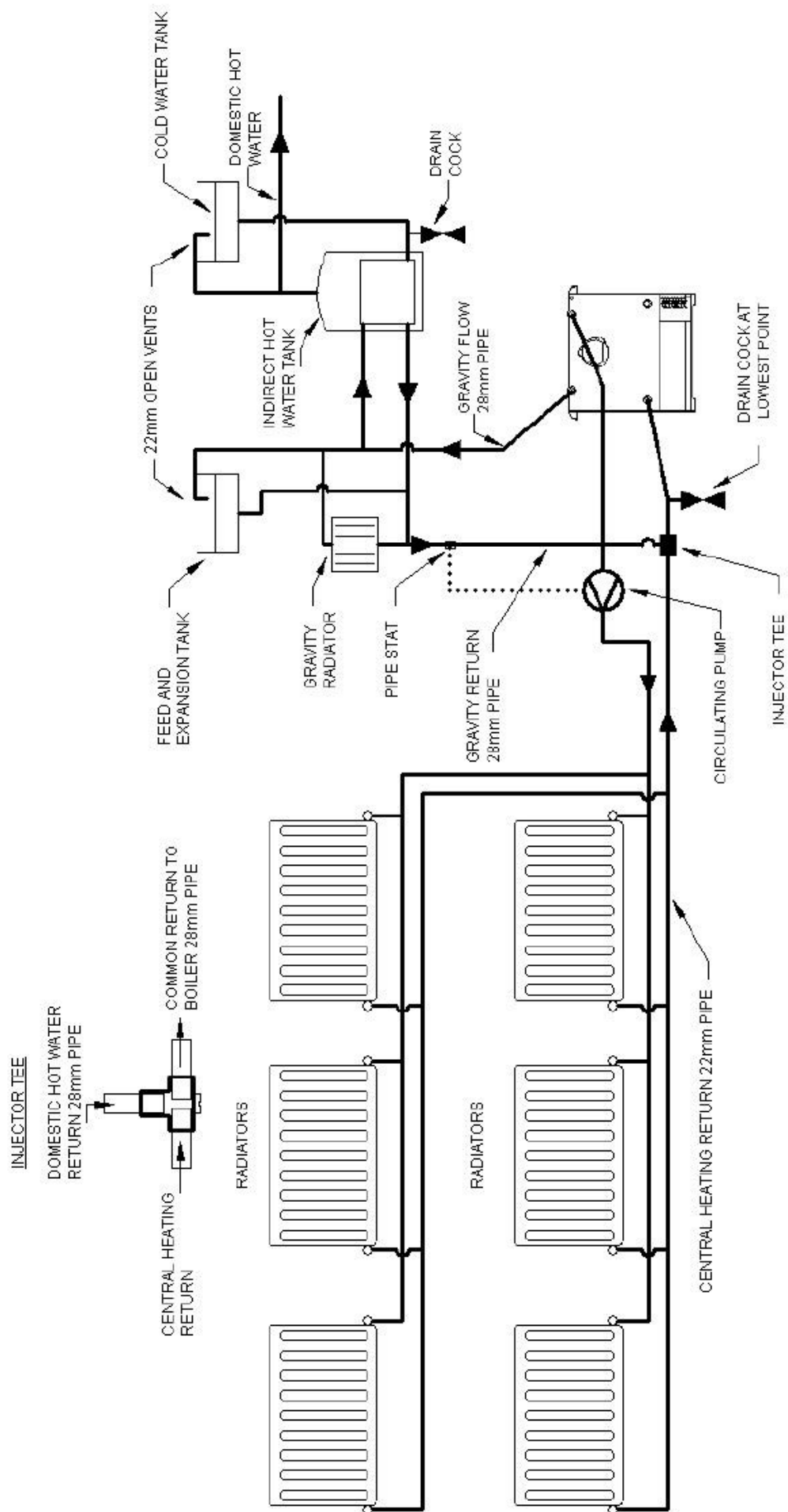

Figure 10: Central heating and domestic hot water system using three boiler tapings.

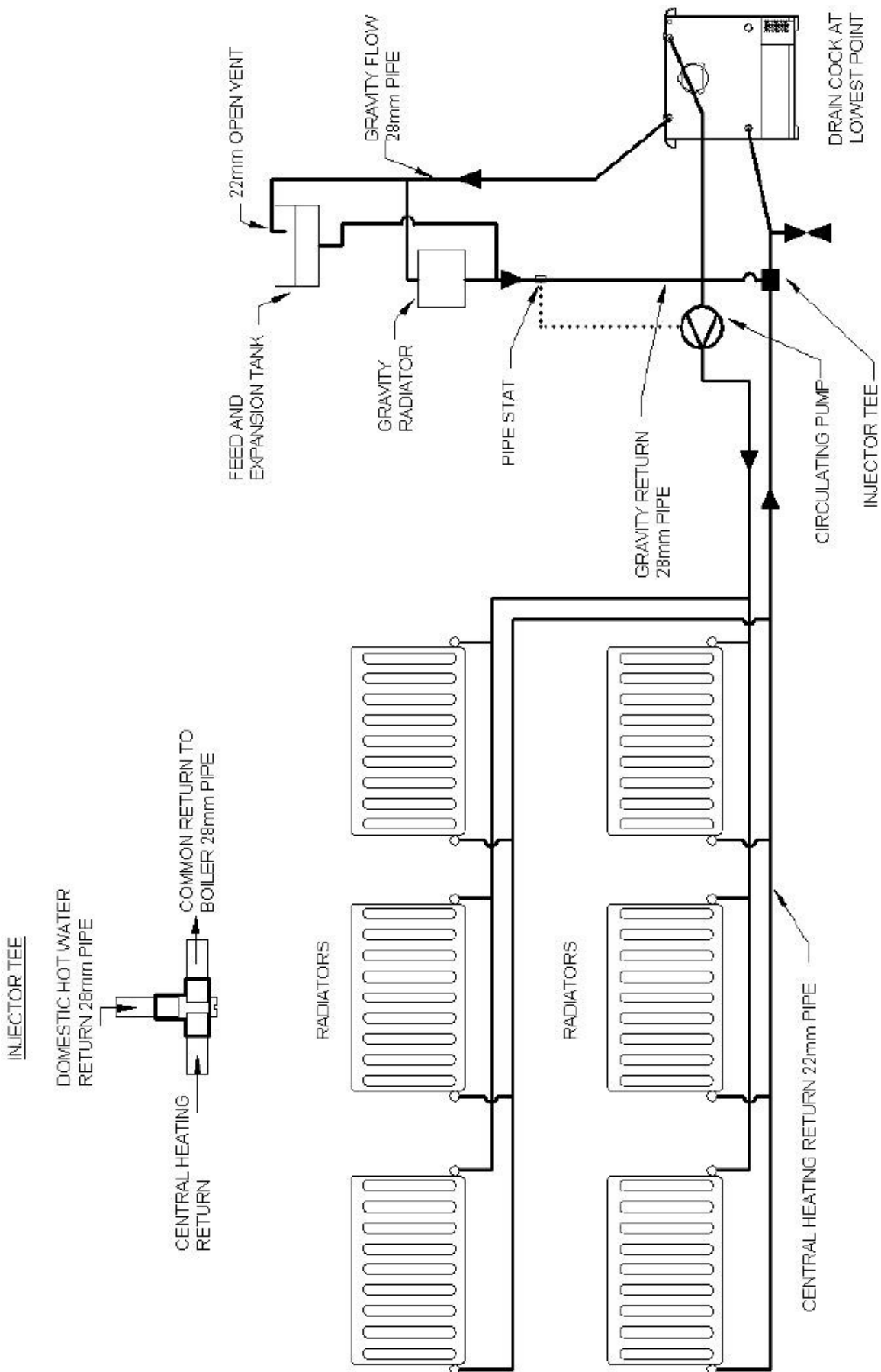

Figure 11: Central heating without domestic hot water system using three boiler tapings.

