

Technical Guide

Glass Replacement : M – Series

TECHNICAL GUIDE—Replacement Glass M-Series

PLEASE NOTE : This technical guide is applicable for the following appliances :

M-Series (All Models) Cast, Glass Or Steel door.



WARNING : HEALTH & SAFETY

- Please ensure the appliance is cold and unlit before commencing fitting the replacement glass.
- Competent persons should only undertake the work detailed in these instructions.
- Please refer to the main instruction booklet, relevant to your stove, for guidance on the installation and operation of the appliance.
- Arada Ltd will not be responsible for any consequential or incidental loss or injury however caused.
- Please consult Health & Safety guidelines for advice on handling heavy and / or large items.
- When lifting, we recommend you always obtain assistance.
- If when manual handling, keep the heaviest load close to the body for as long as possible, good posture is important, face the load to be lifted, bend your knees, ensuring your back is kept straight, ensure a firm grip. Do not twist when you lift.
- When handling glass components, it is recommended to wear suitable gloves and eye protection to prevent hand and eye injuries.

CONTENTS :

STAGE 1: Identification Of M-Series Door Version & Door Removal

STAGE 2: Specific Instructions : Cast Door

STAGE 3: Specific Instructions : Steel Door

STAGE 4: Specific Instructions : Glass Door

TECHNICAL GUIDE—Replacement Glass M-Series

Fitting Instructions :

It is recommended to remove the door assembly and to position onto a suitable protective flat surface to prevent damage to the front face of the door.

STAGE 1: Identification Of M-Series Door Version & Removal

Fully open the fire door. Carefully support the door, from underneath or obtain additional assistance and follow below, depending upon the door version of the stove being worked upon.

Cast Iron Door Version ONLY :

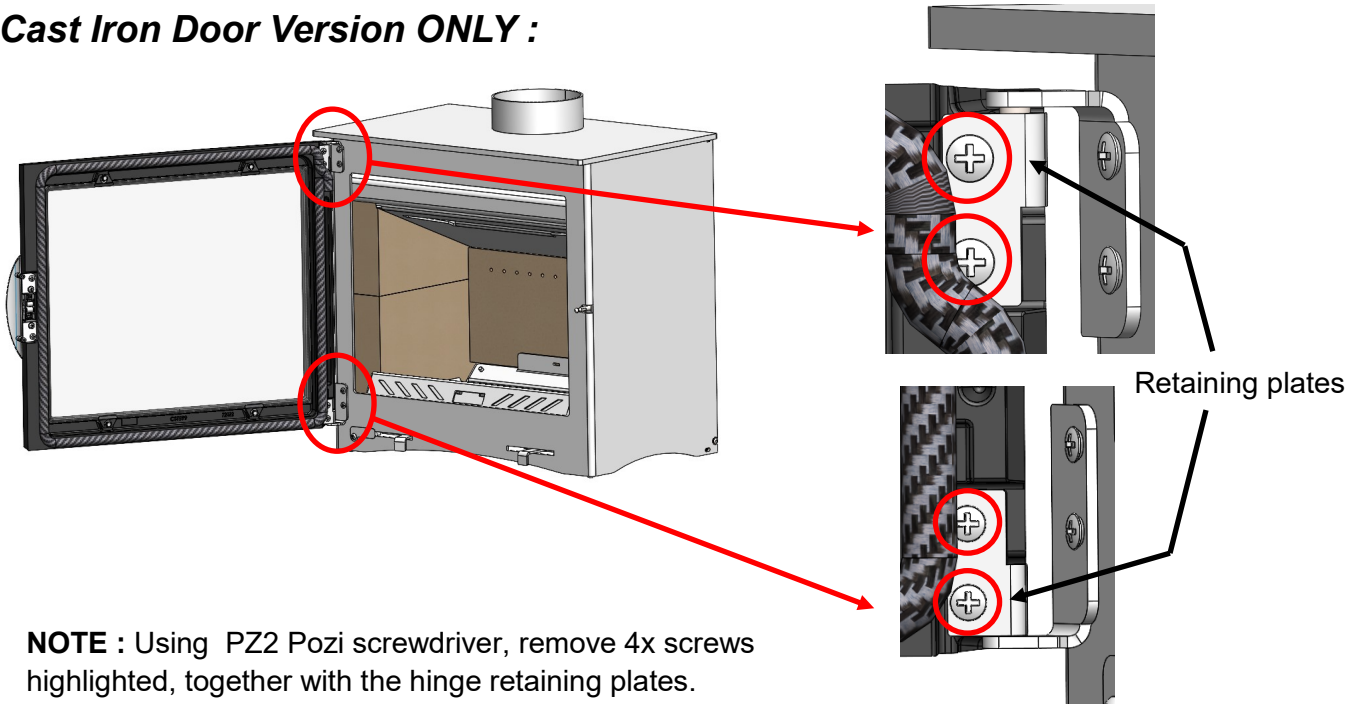

NOTE : Using PZ2 Pozzi screwdriver, remove 4x screws highlighted, together with the hinge retaining plates.

Glass & Steel Door Version ONLY :

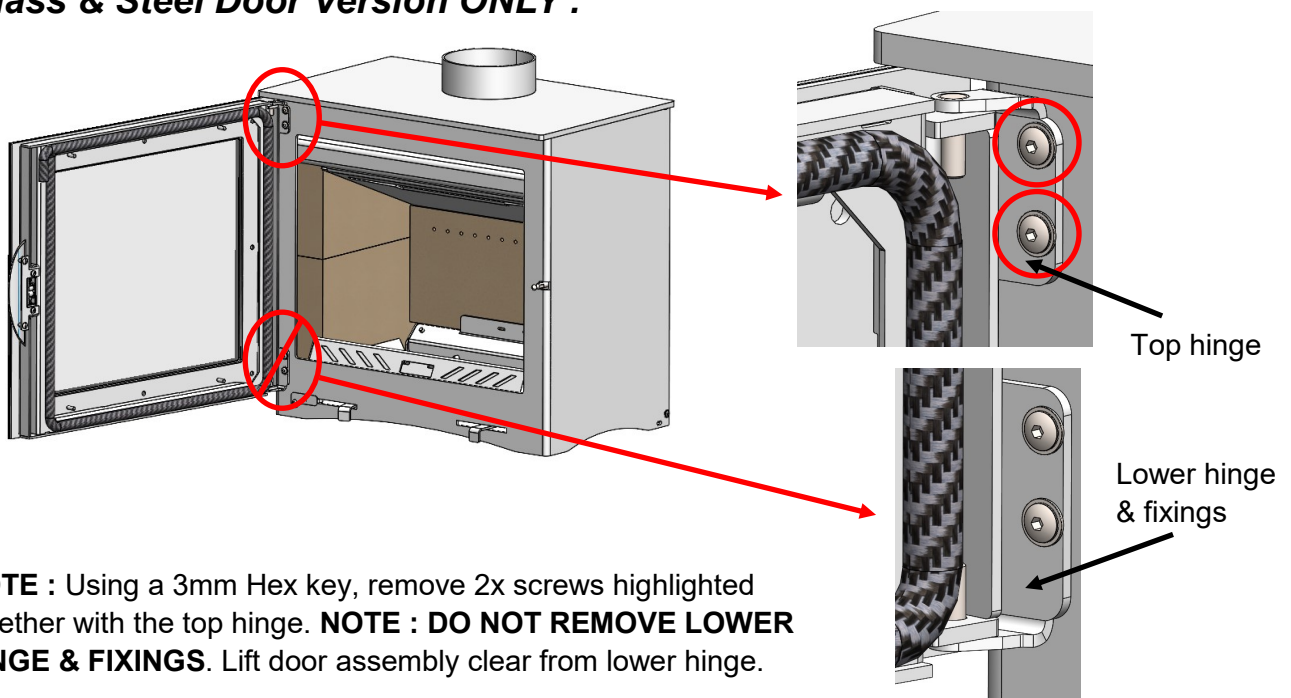

NOTE : Using a 3mm Hex key, remove 2x screws highlighted together with the top hinge. **NOTE : DO NOT REMOVE LOWER HINGE & FIXINGS.** Lift door assembly clear from lower hinge.

STAGE 2: Specific Instructions—Cast Door

With the fire door removed from the appliance, carefully place the assembly onto a work bench or similar level surface, with the FRONT face down onto a soft surface, to prevent damage.

Cast Iron Door Version ONLY :

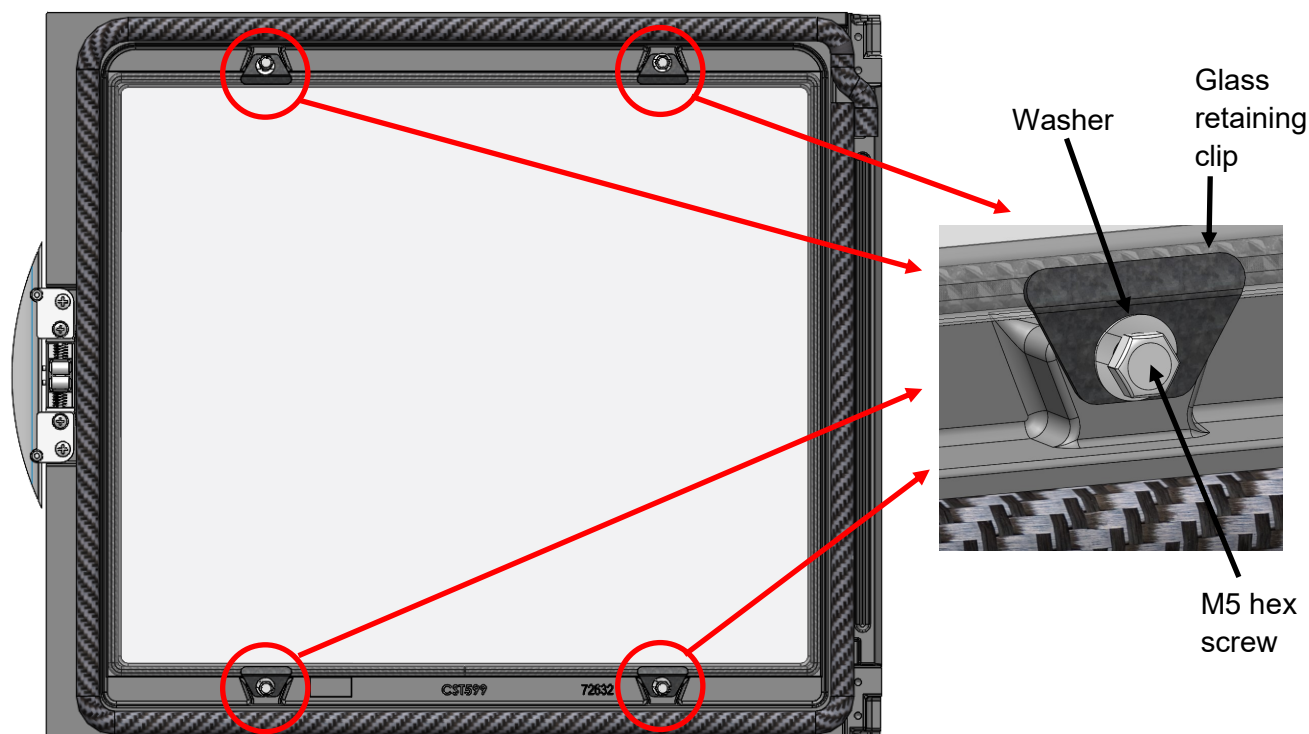

- Using a 8mm spanner or socket remove the 4x M5 x 8mm hex fixings and washers, together with the glass retaining clips.
- Carefully remove any pieces of broken glass and glass sealing gasket, wearing suitable gloves as protection. Take note of the position and joint location of the glass sealing rope gasket. This is generally positioned under one of the lower glass retaining clips.
- Ensure door casting surface is dry and clean, start at centrally at one of the lower glass clip mounts, push the adhesive side of the rope gasket into the groove around the window aperture. Gradually work your way around until the ends of the rope meet, trim excess with knife or scissors.

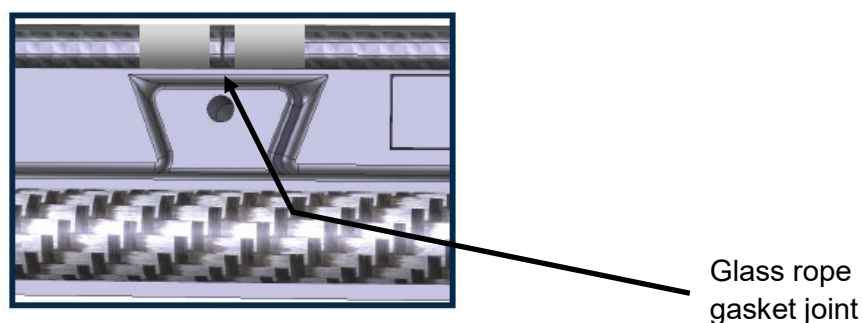

TECHNICAL GUIDE—Replacement Glass M-Series

STAGE 2, Continued :

- Re-seat a new piece of glass, ensuring the glass sits flat against the rope gasket.
- Replace the 4x glass retaining clips, washers and M5 x 8mm hex screws, that were removed earlier.
- **DO NOT OVER TIGHTEN** the fixings, as damage may occur to the glass. The hex screws are only required to be tightened enough to pinch the retaining clips to the glass panel, to prevent movement when you apply pressure with the palm of your hand in a side ways motion against the glass.
- Refit the bottom hinge retaining plate, but do not fully tighten the screws.
- Locate the hinge retaining plate over the bottom hinge pin. Rotate the door assembly horizontal against the top hinge pin.

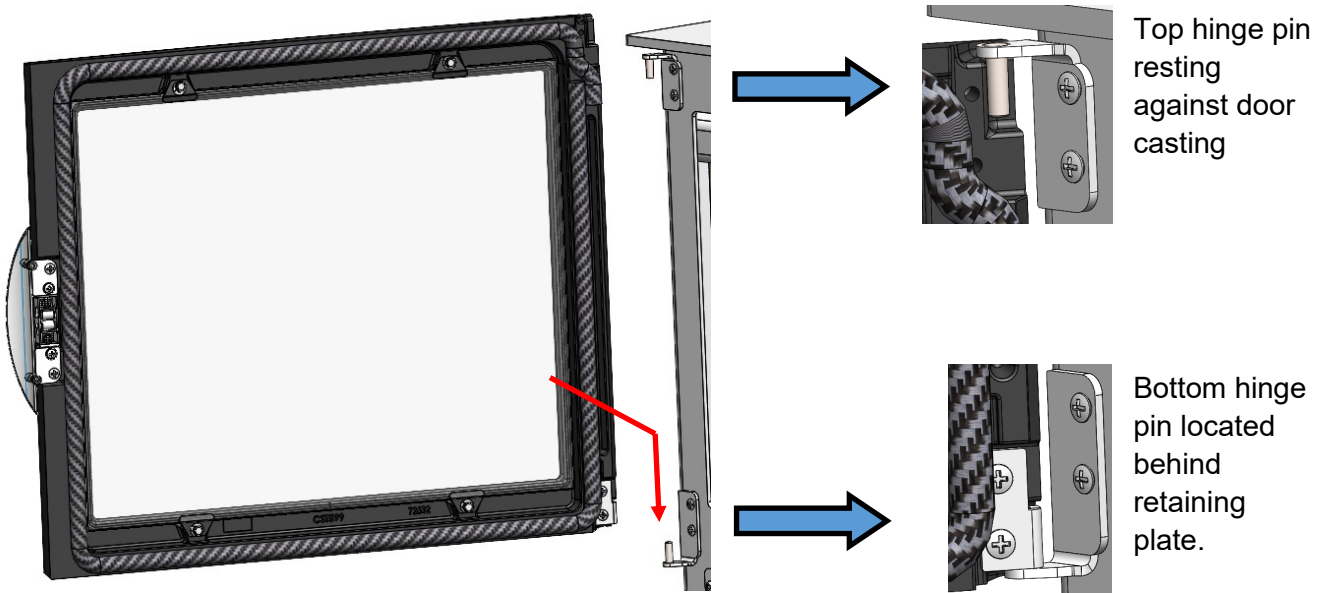

- Refit the top hinge retaining plate and fully tighten screws.
- Fully tighten the bottom hinge retaining plate screws, check operation of door and catch / latching operation.
- If any adjustment is required for the door latching please consult BK 773 (Door catch and pin adjustment for M Series stove), available online at www.aradastoves.com.

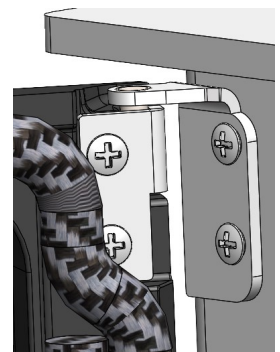

STAGE 3: Specific Instructions—Steel Door

With the fire door removed from the appliance, carefully place the assembly onto a work bench or similar level surface, with the FRONT face down onto a soft surface, to prevent damage.

Steel Door Version ONLY :

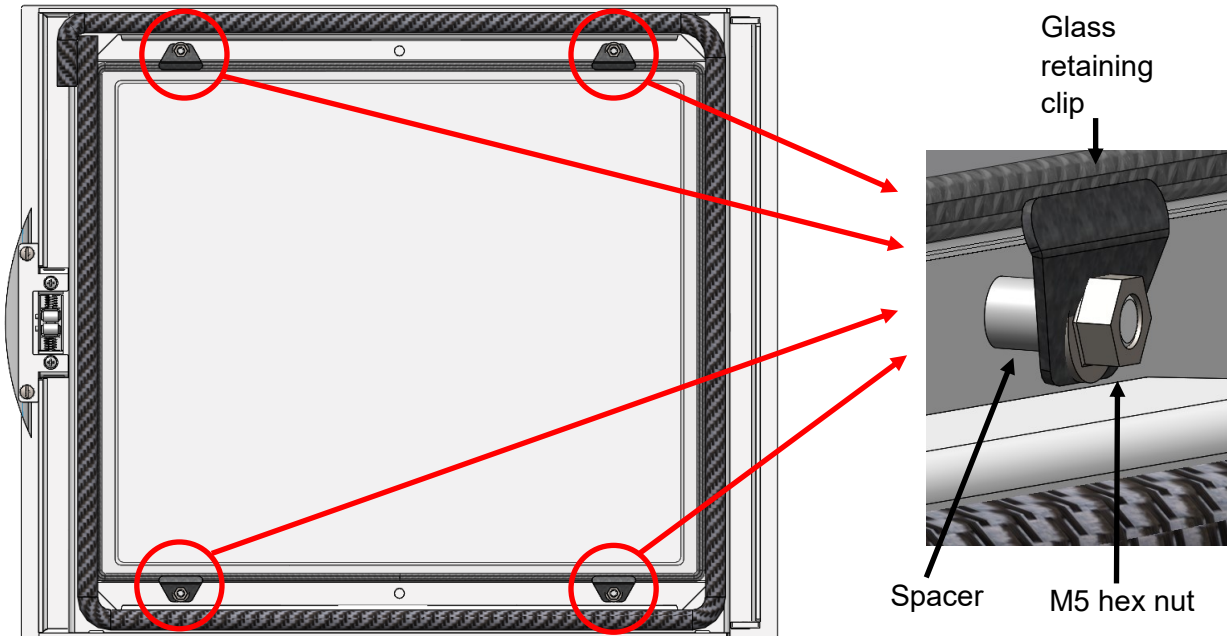

- Using a 8mm spanner or socket remove the 4x M5 hex nuts and glass retaining clips, together with the spacers.
- Carefully remove any pieces of broken glass and glass sealing gasket, wearing suitable gloves as protection. Take note of the position and joint location of the glass sealing rope gasket. This is generally positioned under one of the lower glass retaining clips.
- Ensure the steel door surface is dry and clean, start at one of the lower glass mounts. Place the adhesive side of the rope gasket approximately 10mm in bound from the window aperture (See image below). Gradually work your way around until the ends of the rope meet, trim excess with knife or scissors.

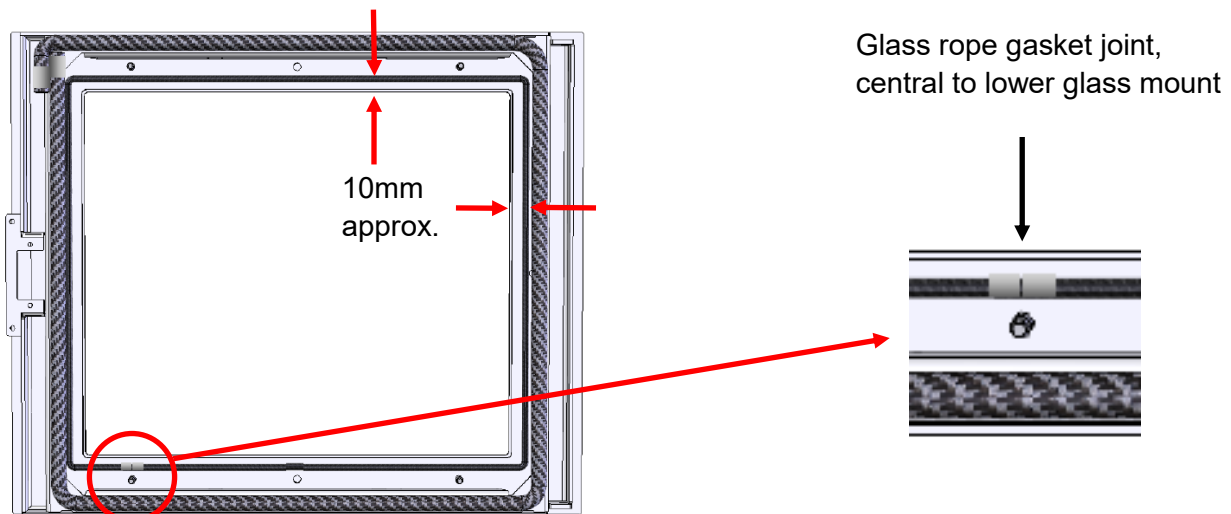

TECHNICAL GUIDE—Replacement Glass M-Series

STAGE 3, Continued :

- Re-seat a new piece of glass, ensuring the glass sits flat against the rope gasket.
- Replace the 4x spacers, 4x glass retain clips and 4x M5 nuts, that were removed earlier.
- **DO NOT OVER TIGHTEN** the fixings, as damage may occur to the glass. The hex nuts are only required to be tightened enough to pinch the retaining clips to the glass panel, to prevent movement when you apply pressure with the palm of your hand in a side ways motion against the glass.
- On the door, locate the bottom hinge hole over the lower hinge pin. Engage the pin and lower onto bottom hinge.

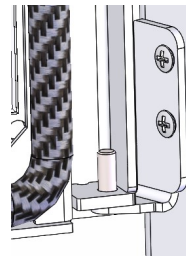
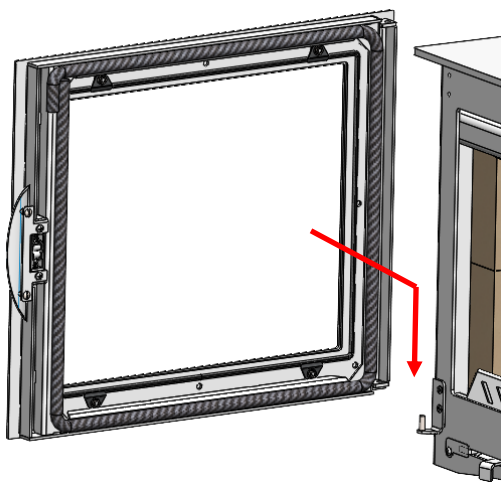

Bottom hinge
pin located

- Drop the top hinge assembly pin into the door and rotate the assembly to meet the hinge holes within the front of the stove body.

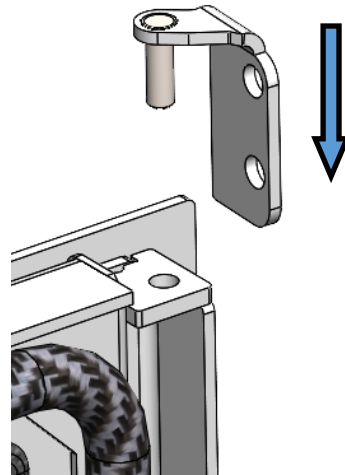

- Affix to stove body using the 2x M5 Pozi head screws, removed earlier.
- Fully tighten screws and check the latching operation of the door catch.
- If any adjustment is required for the door latching please consult BK 773 (Door catch and pin adjustment for M Series stove), available online www.aradastoves.com.

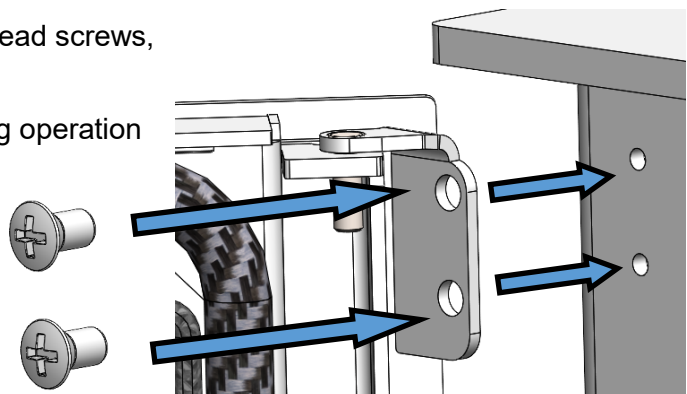

STAGE 4: Specific Instructions—Glass Door

With the fire door removed from the appliance, carefully place the assembly onto a work bench or similar level surface, with the REAR face down onto a soft surface, to prevent damage.

Glass Door Version ONLY :

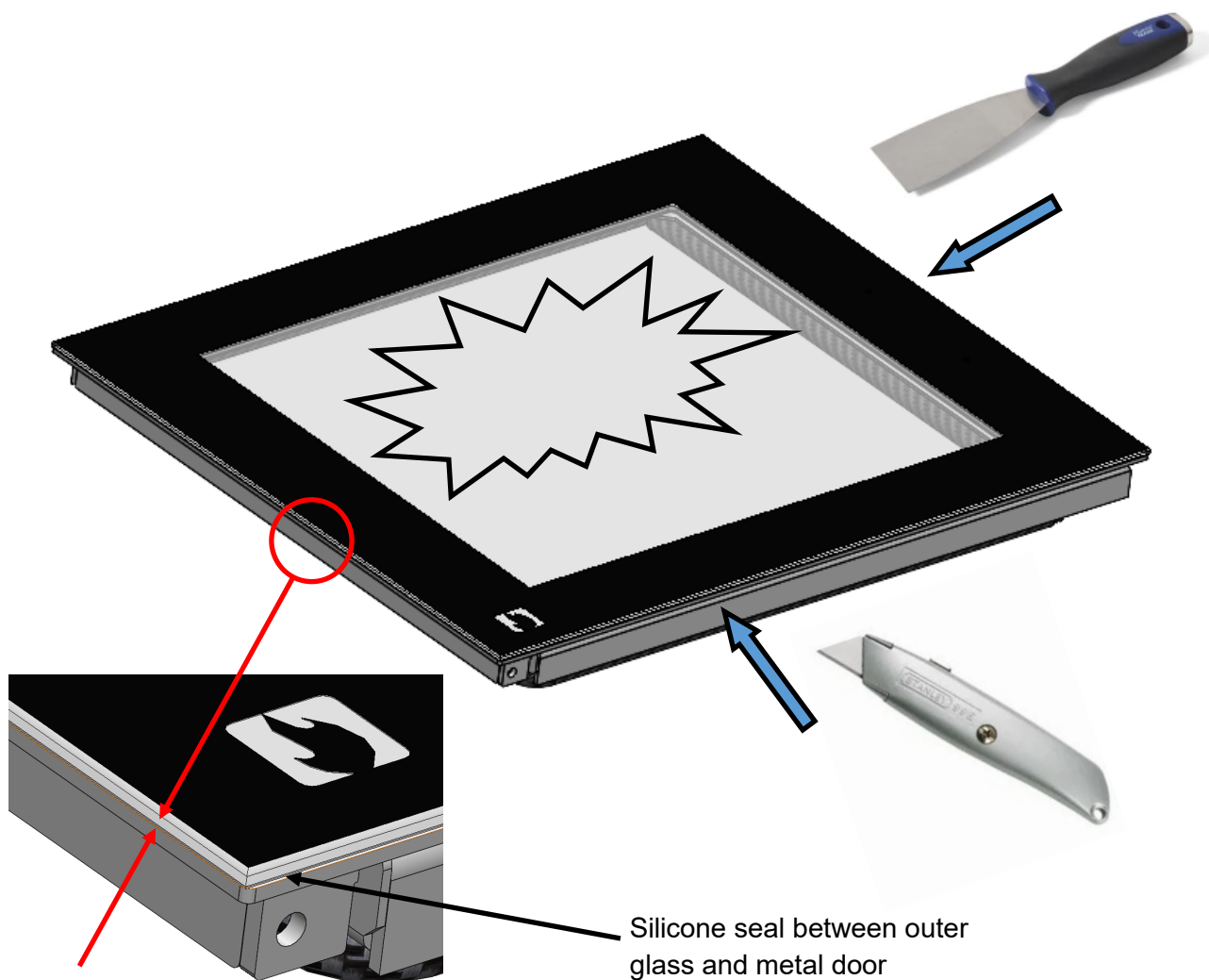

- PLEASE NOTE : Extra care is needed to remove the old damaged glass and adhesive. Always use eye protection and gloves to avoid injuries.
- Using a Stanley knife, score around the silicone seal between the outer glass and the inner door metal frame work.
- Once this has been done, use a flat bladed paint scrapper, prise off the broken glass.
- With all the glass removed, any residual silicone adhesive must be removed, again using the paint scraper or sandpaper remove this old adhesive.
- Clean the inner door metal work surface with a clean rag, please ensure that any remains of the old adhesive are removed, as this will effect the bonding strength of the replacement glass.

TECHNICAL GUIDE—Replacement Glass M-Series

STAGE 4, Continued :

- With the inner door metal work placed as shown on right, take the tube of RTV silicone and cut the nozzle at a 45 degree angle, so that you can produce a bead of silicone approx. at least 3mm in width.



Cut nozzle at 45 Degrees

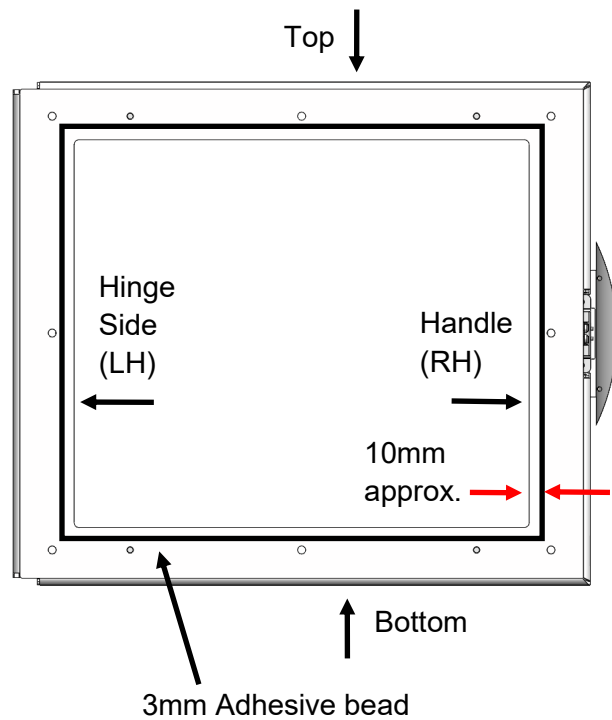

- Apply a continuous bead of adhesive around the window aperture, note, DO NOT apply directly on the edge, keep the adhesive in bound by approx. 10mm (As shown above).
- With the central bead of adhesive in place around the window aperture, apply a zig zag bead of adhesive around the outside, taking care not to apply the adhesive close to the outside edge of the door or in the lower LH area as marked by the red circle, (As shown below) as this will be visible via the emblem in the door glass.

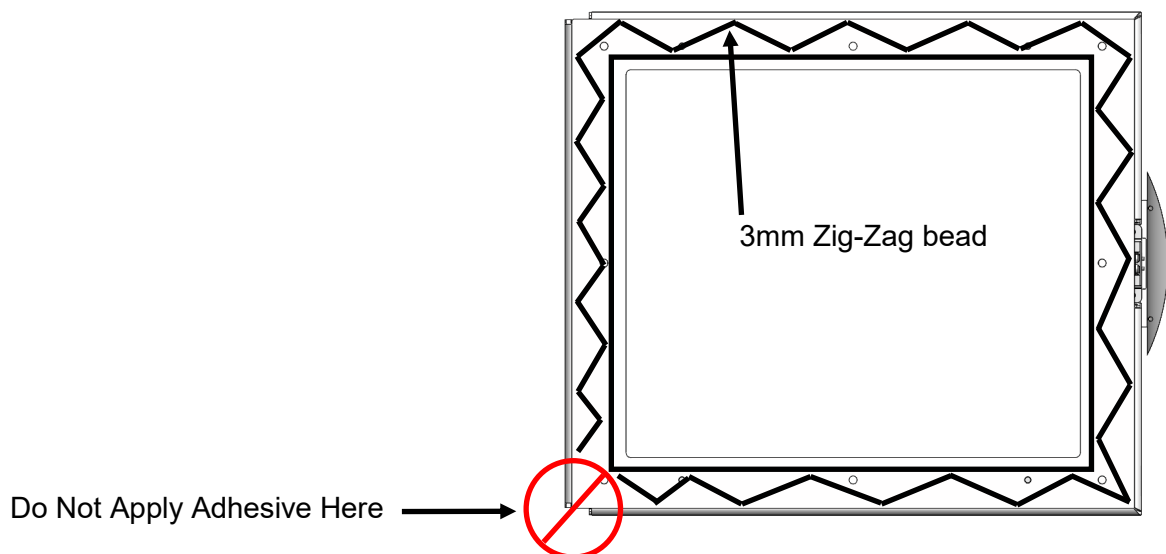

TECHNICAL GUIDE—Replacement Glass M-Series

STAGE 4, Continued :

- Carefully place the replacement glass panel, onto the adhesive NOTE: ensure the emblem is placed in the lower left hand corner (As shown on right).
- Ensure the overhang gap is even on all four sides and apply a gentle pressure to the glass panel, to ensure a good bond with the adhesive. If any excess adhesive is present on the glass, clean this off.

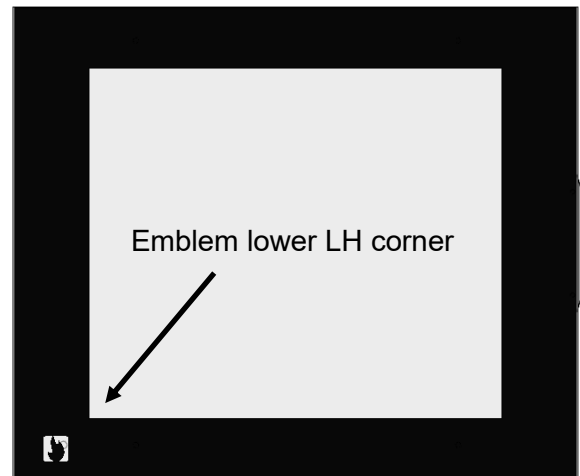

- Leave in a flat (horizontal) position for a minimum of **12 hours**, to allow the adhesive to cure.
- Allowing for the silicone adhesive to cure, locate the door bottom hinge hole over the lower hinge pin. Engage the pin and lower onto bottom hinge.

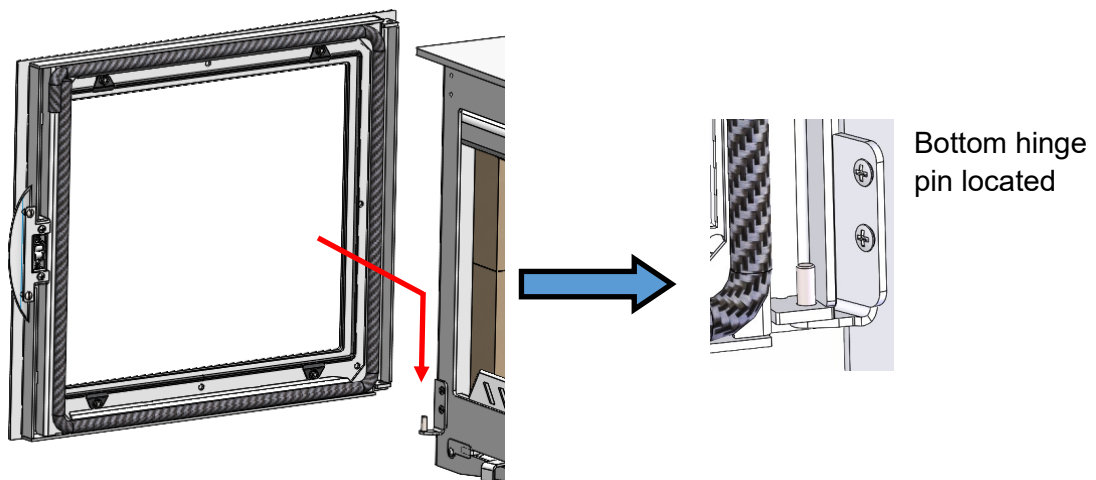

- Drop the top hinge assembly pin into the door and rotate the assembly to meet the hinge holes within the front of the stove body.

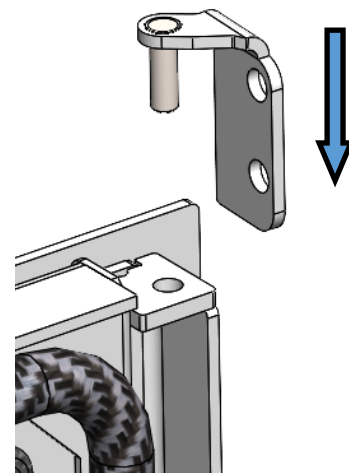

TECHNICAL GUIDE—Replacement Glass M-Series

STAGE 4, Continued :

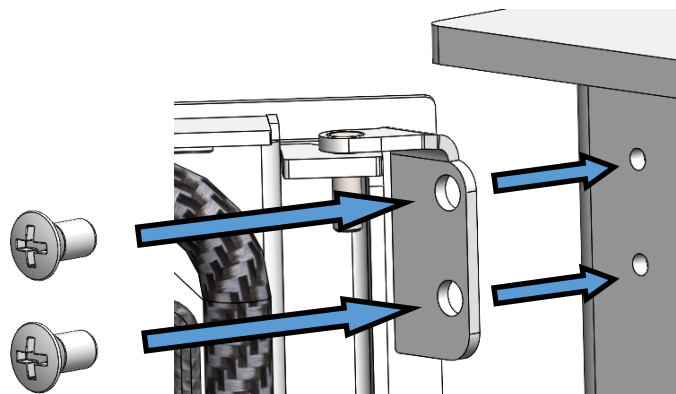

- Affix to stove body using the 2x M5 Pozi head screws, removed earlier.
- Fully tighten screws and check the latching operation of the door catch.
- If any adjustment is required for the door latching please consult BK 773 (Door catch and pin adjustment for M Series stove), available online www.aradastoves.com.

Arada Ltd

The Fireworks, Weycroft Avenue - Axminster - Devon, EX13 5HU, UK
www.aradastoves.com T: +44 (0)1297 632050 Email : info@aradastoves.com



Made In The UK