



Solution (S5) Stove

User Guide

PLEASE RETAIN THIS GUIDE FOR FUTURE REFERENCE

EN 13240:2011 +A2:2004

BK788 Rev 01

ISSUE DATE : 14/10/2025



Congratulations on the purchase of your new stove!

More than 30 years of experience has been put into the development of your stove to ensure ultimate performance and years of trouble free use and enjoyment. Every detail of your stove has been carefully designed and engineered which is why we are so confident in the reliability of our products.

Your stove is built to the highest standard of craftsmanship using the best materials and the most modern equipment available. It is a highly efficient and sophisticated piece of machinery and when properly installed and operated it should provide a lifetime of heating satisfaction.

Should you have any questions about your stove which are not covered by this manual, please contact the your retailer in your area or visit our website :

www.hamletstoves.co.uk which offers a wealth of information on how to care for and get the best from your stove.

Please ensure that you read these instructions in full and understand them before operating your stove.

Hamlet stoves, has a policy of continuous product development and therefore we reserve the right to amend specifications without prior notice.

Due to printing cycles, items or options may be described before they are generally available or after they have ceased. Please check with your retailer or dealer if you are unsure about any aspect of your stove, its installation or correct use.



IMPORTANT NOTE :

The following items are packed inside the stove for shipping purposes :

- 1x Flue Spigot & Fixings
- 1x Hot Plate & Fixings
- 1x Smoke Exemption Restriction Screw (Installation Dependent)
 - 1x Pair Of Stove Gauntlets
 - 1x Operating Tool
- 2x Bolt Down Brackets & Fixings (May come fitted)

Installation of the above items should be carried out by a suitably qualified member of a competent persons scheme or signed off by building control.

Please refer to **BK545, ARADA DRY STOVE INSTALLATION GUIDE** for installation guidance.

For reference all user and installation guides can be downloaded from the Arada website : www.aradastoves.com/support



Hamlet is a brand name of Arada Ltd



Contents

1. Identifying your stove

1.1 Identifying parts & terminology of your stove—External.....	5
1.2 Identifying parts & terminology of your stove—Internal	6

USER GUIDE

2. Warnings

2.1 Important Warnings.....	7
2.2 Health & Safety.....	8
2.3 Smoke Control Areas (The Clean Air Act 1993 & Smoke Control Areas).....	8

3. Recommended Fuels

3.1 Wood.....	9
3.2 Mineral Smokeless Fuel (Solid Fuel)	9

4. Before You Start

4.1 Pointers Before Use	10
-------------------------------	----

5. Air Inlet Controls

5.1 Air inlet	11
5.1.1 Primary air control location.....	11
5.1.2 Primary air control	11
5.1.3 Secondary air control.....	12
5.1.4 Tertiary air	13

6. Lighting Your Stove

6.1.1 Smoke control areas	14
6.1.2 Fuel overloading	14
6.1.3 Operation with door left open	14
6.1.4 Dampers / Air controls left open	14
6.2 Burning wood	14
6.3 Burning solid fuel.....	15
6.4 Warning - Fume / Smoke emissions	16
6.5 Refuelling on to a low fire bed	16
6.6 Smoke Control Area.....	17
6.7 Typical burn for nominal output	17

7. Further Information For All Stove Owners	
7.1 Reduced burning (Slow combustion).....	18
7.2 Over firing.....	18
7.3 Chimney fires.....	18
7.4 Periods of non-use (Summer months).....	18
7.5 Riddling the firebox	19
7.6 Ash removal	19
7.7 Replacement parts.....	20
7.8 Classification.....	20
7.9 Adverse weather conditions.....	20
7.10 Door glass.....	21
7.11 Fire door handle / riddle handle.....	21
8. Care for your stove	
8.1 Adjusting the door hinges	22
8.2 Liners / firebricks	22
8.3 Throat plate.....	22
8.4 Fire door seal	23
8.5 Cracked glass	23
8.6 Chimney / flue sweeping	23
9. Further resources / information	
9.1 Information.....	23
9.2 Specifications	23
10. Guarantee	
10.1 Guarantee	24
10.2 Terms and Conditions	24
10.3 General	25
11. Recycling	
11.1 Packaging Recycling.....	26
11.2 End Of Life Recycling.....	26
12. Technical data.....	27 - 30
13. Additional Information	
13.1 Reduced Distances To Combustibles.....	31
13.2 Twin Walled Flue Reduced Distances.....	31
14. Optional Accessories.....	31

1 Identifying your stove

1.1 Identifying parts & terminology of your stove—*External*

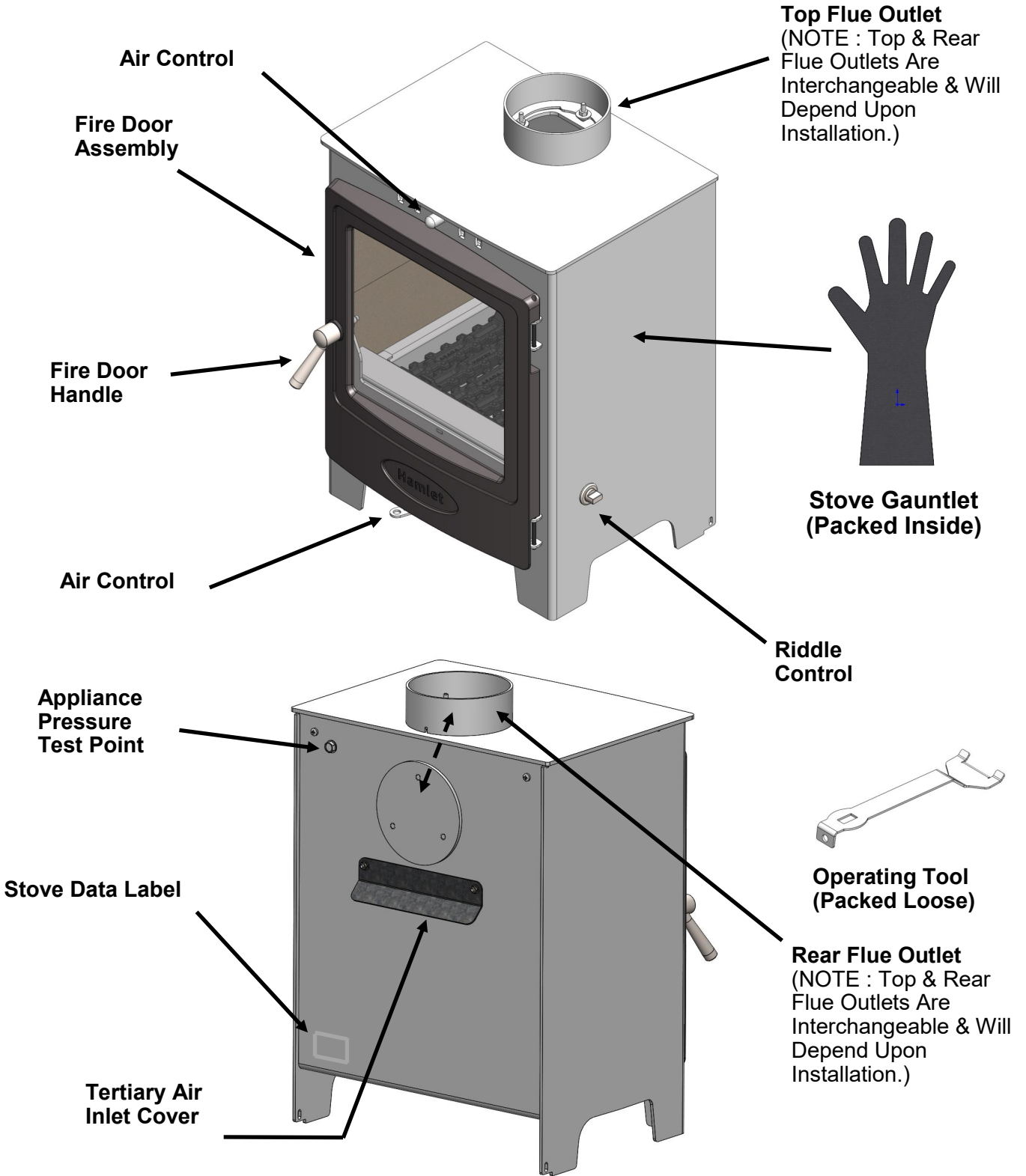

1.2 Identifying parts & terminology of your stove—*Internal*

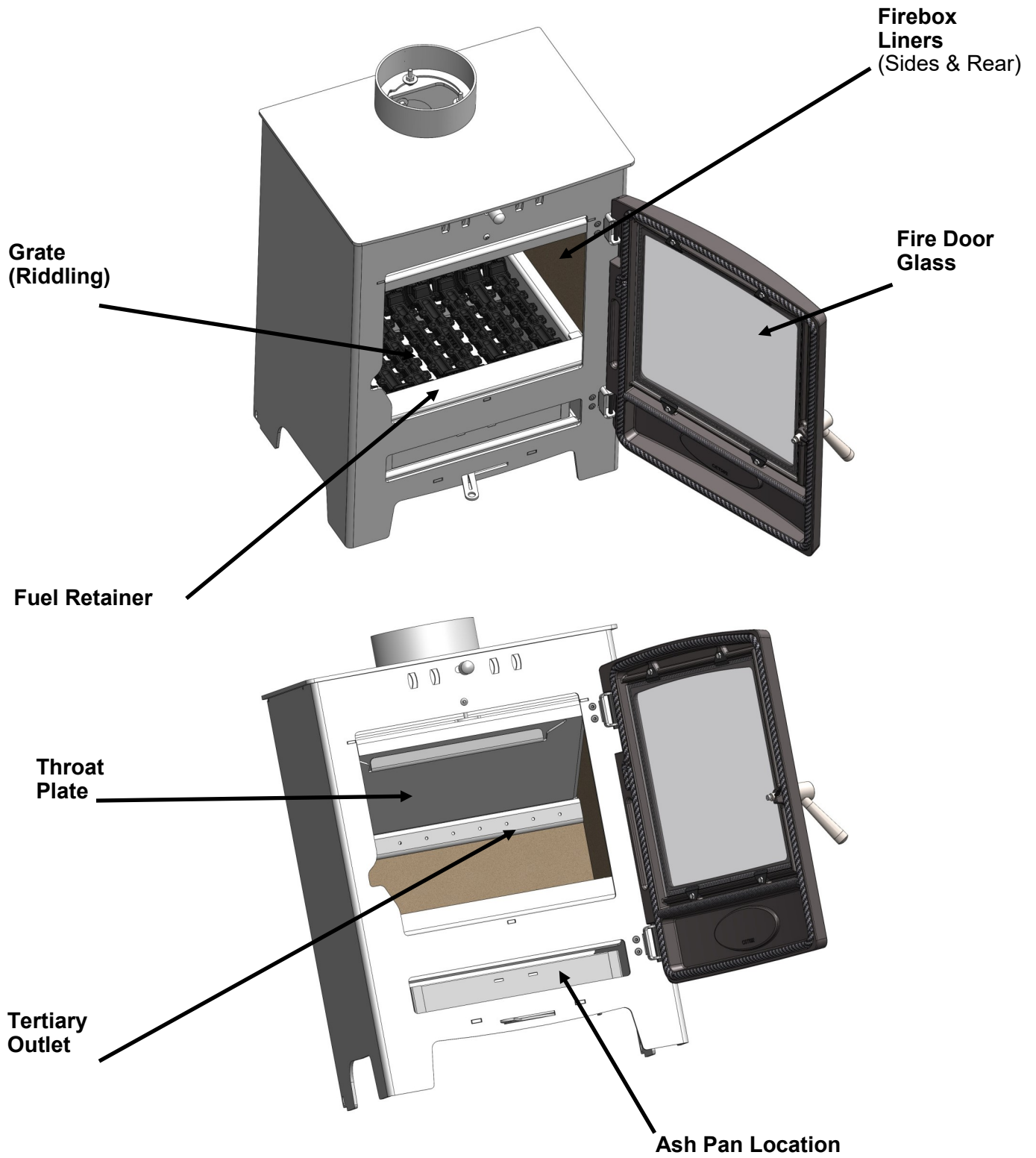



IMPORTANT INFORMATION

2 Warnings—

2.1 Important Warnings

It is a LEGAL REQUIREMENT that the installation of all new or replacement, wood or solid fuel heating appliance, obtain building control approval from your local authority or the installation work must be carried out through a government approved competent persons scheme. A list of all competent person schemes can be found : <https://www.gov.uk/guidance/competent-person-scheme-current-schemes-and-how-schemes-are-authorised>

Any manufacturer's instructions must not be taken as overriding statutory requirements.

All **Solution S5** stoves MUST NOT be connected to a shared flue system.

Please Note: Classification of these appliances is for intermittent use only.

Do not use aerosol sprays or any other flammable materials near the appliance when in use.

Do not use the appliance as an incinerator.

Use only recommended fuels, STRICTLY NO unsuitable and non recommended fuels or materials or liquid fuels allowed.

Pure petroleum coke or Bituminous house coal must NOT be burned in this appliance. The use of these fuels will invalidate the appliance guarantee.

Please ensure that the air inlet vent grills to the dwelling are not obstructed or liable to be blocked.

Caution must be exercised during operation of the appliance as both internal and external surfaces will be hot to touch, use the stove mitten provided when the appliance is in operation.

A fireguard conforming to BS 8423:2002 should be used in the presence of children or elderly people.

Always observe the distances to combustible materials as stated on the appliance data plate and in the technical data section of this manual. Ensure no soft furnishings or combustible materials are susceptible to heat radiating from the appliance.

Under NO circumstances should the stove be operated for extended periods with the main fire door open. This will result in an over firing situation and will lead to severe damage to the stove and flue system.

Ignoring the warnings could lead to damage/injury to persons and/or property.

Hamlet Stoves will not be responsible for any consequential or incidental loss or injury however caused.

It is essential that the appliance has adequate air supply for combustion and ventilation. Apertures provided for this purpose shall not be restricted or covered.

2.2 Health and Safety

Please consult health and safety guidelines for advice on handling heavy and / or large items.

2.3 Smoke control areas (The Clean Air Act 1993 & Smoke Control Areas)

Under the Clean Air Act local authorities may declare the whole or part of the district of the authority to be a smoke control area. It is an offence to emit smoke from a chimney of a building, from a furnace or from any fixed boiler if located in a designated smoke control area. It is also an offence to acquire an “unauthorised fuel” for use within a smoke control area unless it is used in an “exempt” appliance (“exempted” from the controls which generally apply in the smoke control area).

In England appliances are exempted by publication on a list by the Secretary of State in accordance with changes made to section 20 and 21 of the *Clean Air Act 1993* by section 15 of the Deregulation Act 2015. In Scotland appliances are exempted by publication on a list by Scottish Ministers under section 50 of the Regulatory Reform (Scotland) Act 2014.

Similarly in Northern Ireland appliances are exempted by publication on a list by the Department of Agriculture, Environment and Rural Affairs under Section 16 of the Environmental Better Regulation Act (Northern Ireland) 2016. In Wales appliances are exempted by regulations made by Welsh Ministers.

Your local authority is responsible for implementing the Clean Air Act 1993 including designation and supervision of smoke control areas and you can contact them for details of Clean Air Act requirements.

Further information on the requirements of the Clean Air Act can be found here : <https://www.gov.uk/smoke-control-area-rules>

The following list of **Solution S5** models :

- **Hamlet Solution 4 S4** 4kW stove
- **Hamlet Solution 5 S5** 5kW stove
- **Hamlet Solution 5 Widescreen S5** 5kW stove
- **Hamlet Solution 7 S5** 7kW stove

are currently exempt or have been recommended as suitable for use in smoke control areas, when burning wood logs and when fitted with a factory set mechanical stop, to prevent secondary air closure beyond the dimension listed below:

- **Hamlet Solution 4 S5** 4kW stove— 3.5mm Open
- **Hamlet Solution 5 S5** 5kW stove—5mm Open
- **Hamlet Solution 5 Widescreen S5** 5kW stove—4mm Open
- **Hamlet Solution 7 S5** 7kW stove—6mm Open

Please NOTE, by default the smoke exemption screw (mechanical stop) is left off the appliance at manufacture. It is the responsibility of the installer / user to fit the mechanical stop when the appliance is installed within the smoke controlled area.

3 Recommended fuels

3.1 Wood

As a natural and renewable fuel, wood is the first choice for burning, however burning wood requires a little effort and planning.

Any type of wood is suitable (though hardwood is preferable) provided it is well seasoned and has a moisture content below 20%. This usually implies that the timber has been suitably stored to allow moisture to evaporate for at least 9 months in the case of soft wood, and at least 24 months in the case of hard wood. We recommend that for general burning, wood should be split into logs of no more than 100mm (4 inches) diameter.

If, when burning wood, you see signs of sticky tar inside the appliance or chimney, your wood is 'green' or too wet and requires further seasoning. An electronic moisture meter can be obtained in order to determine the moisture content of your wood fuel.

Wet wood must not be used as this will greatly contribute to the creation of tar and creosote which may, in extreme cases, run down the chimney in liquid form. This will seriously damage both the chimney and the appliance and increase the risk of a chimney fire.

3.2 Mineral Smokeless (Solid Fuel)

The appliance has been approved to burn mineral smokeless fuels.

It is important to ensure that your fuel is intended for use in a stove or closed appliance. Modern stoves are designed for use with the cleaner burning and smokeless fuels.

Hamlet stoves, recommends the use of approved smokeless fuels which have been deemed suitable for use on closed appliances including multi fuel stoves or boilers. Authorised fuels suitable for Smoke Control Areas, please see (<https://smokecontrol.defra.gov.uk/fuels>)

For additional advise on fuels, please refer to the Solid Fuel Association (www.solidfuel.co.uk)

DO NOT BURN Bituminous house coal or petroleum coke in this appliance.

PLEASE NOTE : All test data, outputs and efficiencies stated in this instruction manual were obtained by burning 'Maxibrite' mineral smokeless fuel.

DO NOT BURN Any form of plastics in this appliance.

4 Before using your stove

4.1 Pointers Before Use

Solution S5 stoves are designed to be operated with the fire door(s) closed at all times, apart from refuelling (when alight) or cleaning (when cold).

Never leave the appliance unattended for an extended length of time with the door(s) open.

Prior to lighting the stove for the first time, please check with the installer that:

- Installation and all building work is complete. (Refer to the installation guide **BK545**)
- The chimney is sound, has been swept and is free from obstruction.
- Building Regulations and any local by-laws have been followed during installation.
- All firebox liner panels and throat plate are in place.
- The chimney draw has been checked and is within specification (between 0.12mb to 0.2mb, or 12-22 pascals). This ensures your stove will operate predictably and efficiently.
- Carbon Monoxide detector is correctly installed in the same room as the appliance.
- Suitable provision for combustion and ventilation air, depending upon building regulations have been undertaken by the installation fitter.
- Consideration must be given for the need for extra ventilation if another heating source needing air is to be operated simultaneously. If an extraction fan is proposed to be fitted to a connecting area of the house, after the stove has been installed, professional advice should be sought from a qualified engineer.

Ensure that you have read and understood these instructions before lighting the fire.

Always wear suitable protective fire gloves when refuelling your stove, such as the hot glove supplied with your stove. Always keep the hot glove away from naked flames and sparks, when re-fuelling the appliance.

We recommend that you light a small fire for the first few days of use to cure the paint and allow the castings to relax.

You may hear your stove produce clicking or ticking noises whilst it heats up or cools down. This is completely normal and is produced by the expansion and contraction of the steel components in your stove when its temperature changes.

5 Air inlet controls

5.1 Air Inlet

Your stove requires air to function, this enters the appliance at 3 points; above the fire door on the front of the stove, via the duct at the rear of the stove and beneath the appliance.

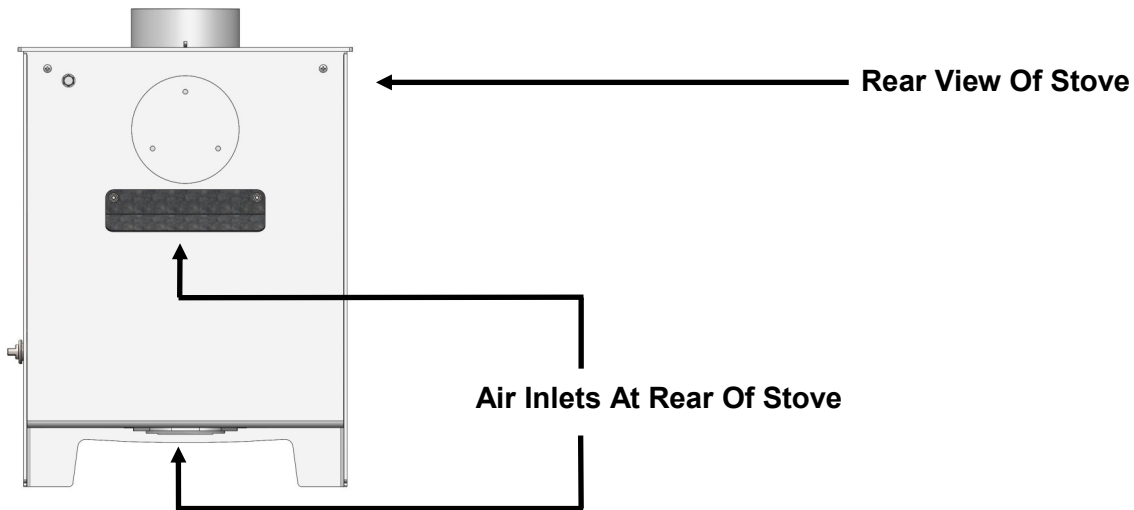

NOTE : DO NOT COVER OR PARTIALLY OBSTRUCT THE AIR INLET OPENINGS FOR THE APPLIANCE.

5.1.1 Primary air control location

The primary air control, regulates the air entering the fire box chamber, supplying air below the grate. This control is situated below the fire door, centrally on the stove, when facing the front of the stove.

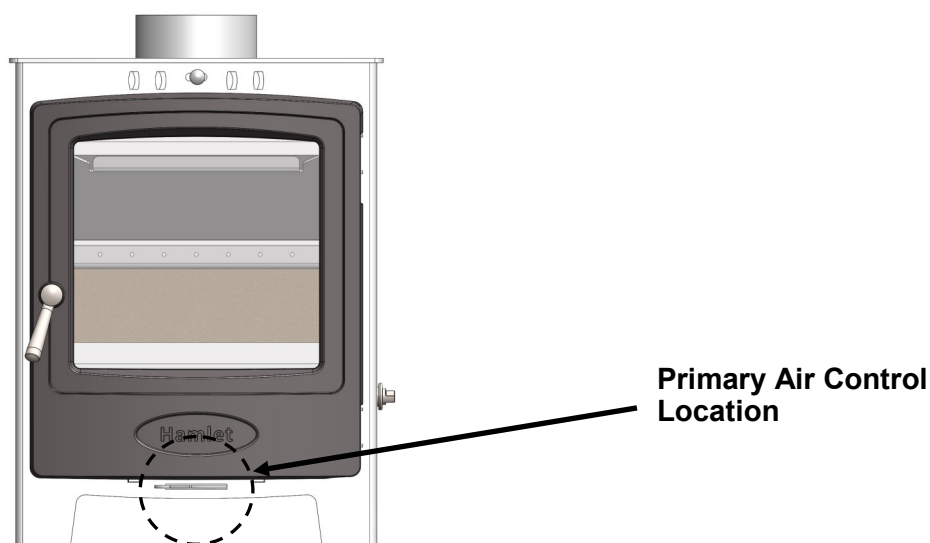

5.1.2 Primary air control

The primary air control regulates the air entering the fire box chamber, supplying air to the under side of the fuel bed.

The control has an internal rotary plate with slots, housed inside the body of the appliance and is located centrally below the fire door assembly.

Sliding the control knob to the right, as far as it will go, achieves the fully open position, see figure 1. Sliding it to the left will shut down / reduce the air as shown in figure 2.

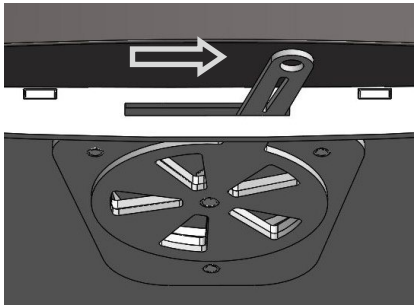

Fig. 1. Fully Open Position

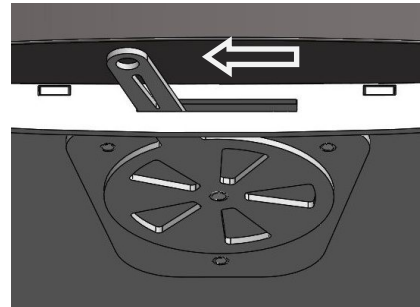

Fig. 2. Fully Closed Position

5.1.3 Secondary air control

The secondary air control regulates the air entering the fire box chamber, supplying an overdraft of air to the fuel bed, together with supplying air in front of the glass viewing panel within the door assembly. This is known also as the air wash system.

This control is situated, centrally above the fire door, when facing the front of the stove.

Secondary Air Control Location

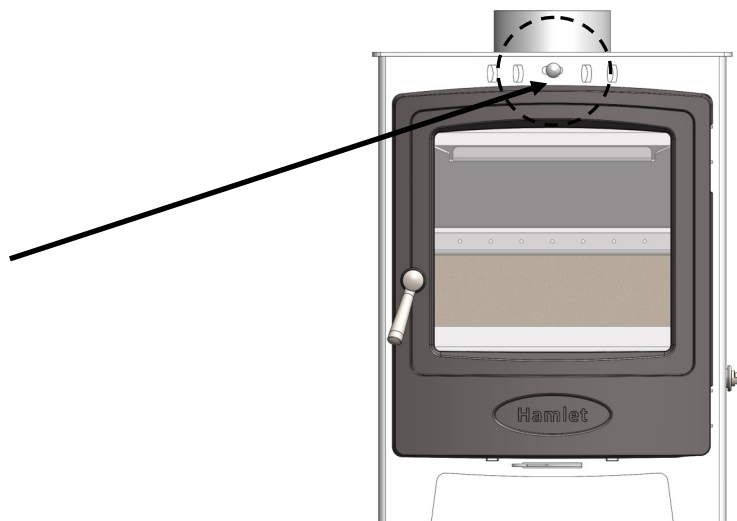

The control has an internal sliding plate with slots, housed inside the body of the appliance and is located centrally above the fire door assembly, when looking at the front of the appliance.

Sliding the control knob to the right, as far as it will go, achieves the fully open position, see figure 3. Sliding it to the left will shut down / reduce the air as shown in figure 4.

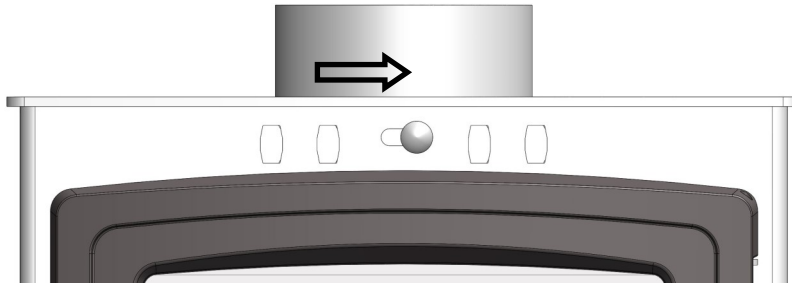

Fig. 3. Fully Open Position

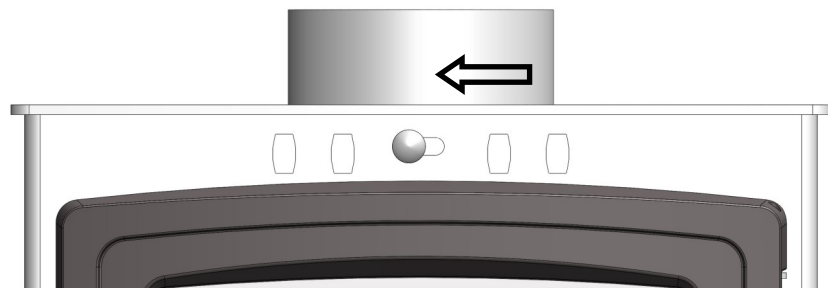

Fig. 4. Closed / Reduced Position



NOTE : If your stove installation is within a smoke control area, it will be fitted with a restrictor screw, acting as a mechanical stop for the secondary air control. This will not fully close, thus allowing a bleed of air to the fire box to reduce smoke emissions.

5.1.4 Tertiary Air

All models have tertiary air supply that can be seen working during certain conditions during the burning period. The outlet for the tertiary air, is at the rear of the fire box chamber, just below the throat plate through a series of small holes within a rectangular chamber (See page 6).

Tertiary air is employed, to provide additional air to the upper areas of the fire box to promote additional burning of the unburnt combustion gases and thus ensuring a cleaner burn emission.

There is no user adjustment required for the tertiary air, as the required air supply is factory set during the production process.

6 Lighting your stove

6.1.1 Smoke control areas

Please check whether your dwelling is located in a smoke control area before installation or use. Please check with your local authority or <https://www.gov.uk/smoke-control-area-rules>.

6.1.2 Fuel overloading

The maximum amount of fuel specified in this manual should not be exceeded, overloading can cause excess smoke. Please see technical data section in this manual.

6.1.3 Operation with door left open

Operation with the door open can cause excess smoke. The appliance **MUST NOT** be operated with the appliance door left open except as directed in the instructions.

6.1.4 Dampers / Air controls left open

Operation with the air controls or appliance dampers open can cause excess smoke. The appliance must not be operated with the air controls, appliance damper or door left open except as directed in these instructions.

6.2 Burning wood

When wood is burnt, it is in fact the volatile gases released from the wood, that burn and this requires a good supply of air coming from above the fuel.

For this reason we will use all the air inlets while igniting the stove, but will then reduce this to air coming from the air wash system and over draught. As much as 40% of the heat from burning wood is obtained from secondary combustion and this can be severely hampered by air entering the fire box from below the fuel.

- 1) Set the fire, by placing several layers of dry kindling wood into a criss-cross grid pattern on top of the grate bars. The use of two or three fire lighters may assist in lighting the kindling.
- 2) Fully open the primary and secondary air controls and light the fire lighters and or kindling wood.
- 3) After the kindling has caught light, you should almost close the fire door leaving it ajar by about 10mm. This will aid flue draw during the initial lighting of the fire.
- 4) The flue temperature and draw should be established after five minutes and the kindling reduced to form an ember bed. Carefully load the stove with well seasoned wood and fully close the fire door.
- 5) After ten minutes, fully close the primary air control and regulate the secondary air control to control the burn rate and maintain clear glass, typically by reducing to approximately half open.

6.3 Burning solid fuels

Solid fuel burns best with its air supply for combustion coming from underneath the fuel. To achieve this, the burn will be controlled by the primary air control.

A reduced setting may also be required on the secondary air control, to maintain clear glass on the door assembly.

Riddling the stove occasionally will also help to ensure that burnt fuel does not prevent the supply of air from reaching the fuel bed.

The procedure for lighting / burning solid fuel, is as follows : -

- 1) Set the air wash (secondary) air control to about one quarter open and the primary air control fully open.
- 2) Lay the fire by using several layers of dry kindling wood into a criss-cross grid pattern on top of the grate bars. The use of two or three fire lighters may assist in lighting the kindling.
- 3) After the kindling has caught light, you should almost close the fire door leaving it ajar by about 10mm. This will aid the flue draw during the initial lighting of the appliance.
- 4) Once the flue draw has been established, after about five minutes, carefully load the stove with solid fuel, it is suggested that the initial loading is best done using fire tongs and placing the fuel, rather than shovelling the fuel.
- 5) When the fire is well alight regulate the burning rate by controlling the primary air control.
- 6) The secondary air control (air wash) should be closed enough to enable a sufficient supply of air to the glass to keep the door glass clean.
- 7) Whilst burning solid fuel it can be beneficial to occasionally riddle the grate bars so any burnt fuel will fall between the grate bars into the ash pan. Please see 'Section 13—Further Information' on the procedure for riddling.

6.4 Warning - Fume / Smoke emissions

Properly installed, with a suitable flue or chimney, operated and maintained correctly, this appliance will not emit fumes into the dwelling. Occasional fumes when de-ashing and refuelling may occur. However, persistent fume emission is potentially dangerous and must be investigated by an approved / registered installer.



WARNING!

STOP USING THE APPLIANCE IF YOU SMELL FUMES OR SEE SMOKE ESCAPING.

If fume emission does persist, the following immediate actions should be taken:

- Open doors and windows to ventilate room.
- Let the fire die or extinguish and safely dispose of fuel from the appliance.
- Check for flue or chimney blockage, and clean if required.

Seek expert advice from your approved installer.

Do not attempt to re-light the fire until the cause of the fume emission has been identified and corrected.

6.5 Refuelling on to a low fire bed

If there is insufficient burning material in the fire bed to light a new fuel charge, excessive smoke emission can occur. Refuelling must be carried out onto a sufficient quantity of glowing embers and ash that the new fuel charge will ignite in a reasonable period. If there are too few embers in the fire bed, add suitable kindling for ignition to prevent excessive smoke.

Important notes on usage, to meet the requirements of Smoke Control exemption -

- **Always recharge onto hot embers.**
- **After re-charging, fully open both the primary and secondary air controls for the following times, in order to establish good combustion -**
 - Hamlet Solution 4kW S5—3 minutes with the fire door ajar**
 - Hamlet Solution 5kW S5—2 to 3 minutes**
 - Hamlet Solution 5KW Widescreen S5—3 minutes with door ajar**
 - Hamlet Solution 7kW S5—3 minutes with door ajar**
- **Do not leave the appliance unattended until flames are well established.**
- **Periodic burning out of the fuel bed at high output to combust any remaining charcoal.**

6.6 Smoke Control Area (The Clean Air Act 1993 & Smoke Control Areas)

If the stove is to be installed in a designated Smoke Control Area (further information can be found via <https://www.gov.uk/smoke-control-area-rules>) then the installer will have fitted the a restrictor screw for the secondary air lever to prevent total closure of this air control.

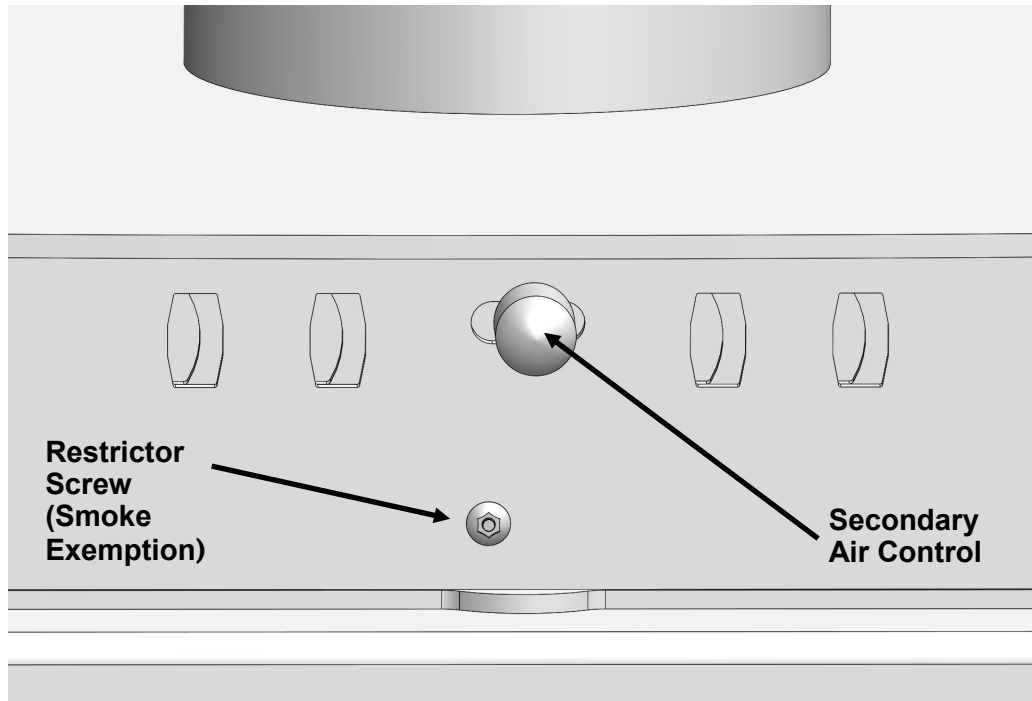

Fig. 5. Fitted Smoke Exemption Restrictor Screw



NOTE :

The minimum air control setting is governed in manufacture to meet the requirements of Smoke Control exemption and as a result the appliance will **NOT** shut down completely when in the minimum air position setting.

Removal or modification of the fitted air control fixing (See Fig. 5) is illegal when the appliance is installed in a smoke exemption area and doing so may result in prosecution and fine.

6.7 Typical burn for nominal output

To perform the most efficient burn at the nominal rated output please consult the specification table at the rear of this manual. Please note, many factors can effect the nominal output, so the stated weights of fuel (Seasoned hard wood, Beech and Mineral solid fuel, 'Maxibrite') are a guide, which is a representation to laboratory test burn conditions.

7 Further information for all stove owners

7.1 Reduced burning (Slow Combustion)

When wood is burnt slowly in a closed appliance (eg: air controls at the minimum setting), it produces moisture and tar, which will create condensation and deposits in the chimney. This effect can be minimised by burning hard for a short period, fifteen to twenty minutes twice a day.

To avoid chimney problems your appliance should not be burnt at a reduced burn rate without a period of fast burning. Fast burning is when the stove is burnt with a 'lively flame' and a higher temperature. We strongly advise against stoking the fire with wood and reducing the air inlets before leaving the stove to extinguish (perhaps when retiring to bed) as this can lead to a cooling of the stove and flue also resulting in incomplete combustion, sooty deposits and high levels of pollutant gases released into the environment.

7.2 Over firing

DO NOT over fire your appliance. Firing the stove at maximum for prolonged periods may result in over-firing. If the chimney connector or casing glows red the appliance is being over-fired and this may result in a chimney fire. Other signs include warping and a red-oxide colouring will demonstrate the over- heating of internal parts; body paint which has turned dusty white is also indicative of such use.

7.3 Chimney fires

Used in the correct manner, with the correct fuel and regular maintenance a chimney fire should never occur, however in the even of a chimney fire, the following procedure should be actioned without delay:

- **Call the fire service—DIAL 999**
- **Immediately close all of the air inlet supplies on the appliance, to reduce the air supply to the stove.**
- **Move items of furniture and combustibles away from the surrounding area of the stove, to reduce the risk of fire and allow access for the fire service.**
- **Ensure access to the loft space is available.**
- **Evacuate the property.**

7.4 Periods of non-use (summer months)

Please ensure that your stove is left clean and moving components are well lubricated with a water repelling corrosion inhibitor for the summer months (during periods of prolonged non-use). If possible store the throat plate outside of the stove. Check all moveable components at regular intervals, to ensure they are moving freely.

Allow air movement through the stove by opening the primary air inlet control to about half way, open or leave the door ajar. This will allow a free flow of air through the appliance thus preventing moisture and condensation forming inside the stove and chimney.

This preventative maintenance will ensure your stove stays in the best condition for the coming winter months.

7.5 Riddling the grate

To riddle the grate, please keep the main fire door closed to prevent ash, from discharging from the firebox.

Using the glove supplied, locate the operating tool onto the riddling boss, located on the right hand side of the appliance. Moving the operating up and down repeatedly, will result in agitating the grate bars and thus allowing ash to drop into the pan

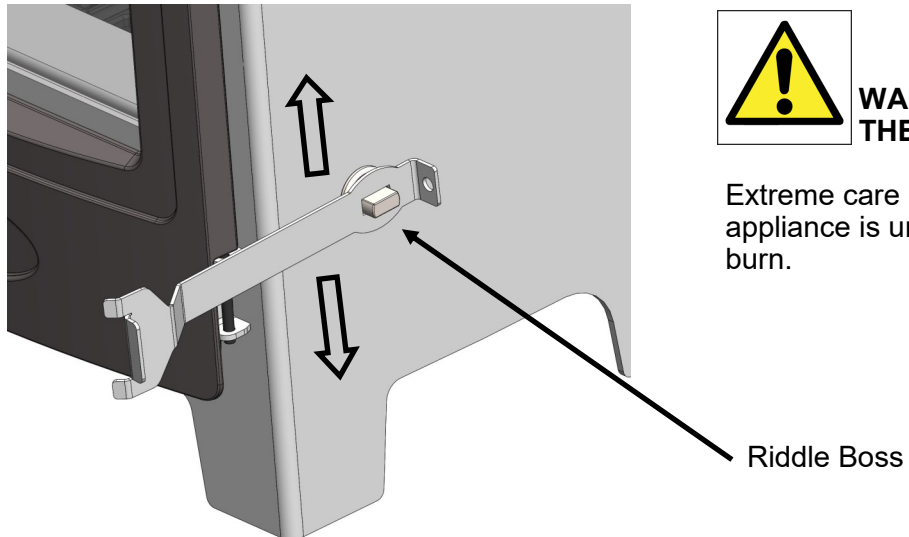

WARNING : ALWAYS USE THE GLOVE SUPPLIED.

Extreme care must be taken if the appliance is under fire, risk of injury or burn.

Fig. 6. Riddling The Grate

7.6 Ash removal

The ash pan should be emptied when the level of ash reaches the top of the ash pan. On no account should the ash be allowed to build up to touch the underside of the grate, as this will greatly reduce the life span of the grate.

To remove the ash pan **ALWAYS USE** the supplied glove & operating tool -

- Open the door of the stove, pausing briefly when ajar so as to allow the fire to adjust to the increased air supply.
- Insert the fork end of the operating tool into the ash pan (see Fig. 7.).
- Carefully withdraw the ash pan from the ash pit chamber.
- Empty the ash into a suitable metal container. Replace the ash pan into the stove, reversing the above procedure and close the fire door.



WARNING : Ash can be very **HOT!!**. Care must be taken not to burn hands or household objects with falling embers—**ALWAYS USE THE GLOVE SUPPLIED.**

Empty only into a metal container. Even if the ash appears cold, red hot embers maybe concealed and could easily start a fire or cause an injury.

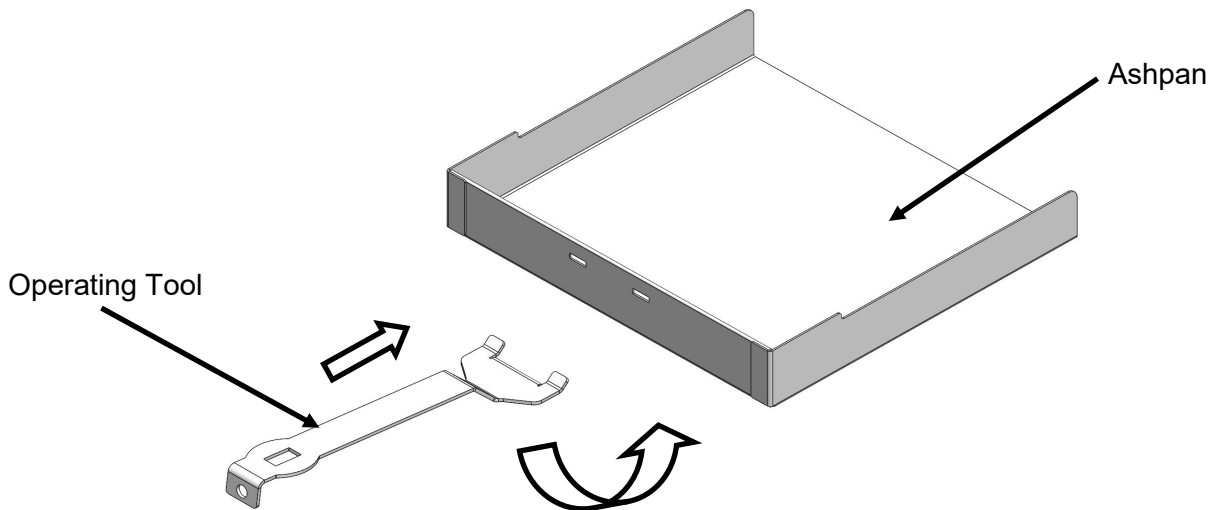

Fig. 7. Ash Pan

7.7 Replacement parts

Genuine replacement spare parts can be obtained from your **Hamlet stoves** retailer / dealer.

You can find a complete list of spares and consumables such as liners, replacement grate parts and throat plates as well as items to enhance its visual appearance and efficiency such as stove paint and rope kits.

It is worth noting that the fitting of non-official parts to your stove will invalidate its guarantee.

7.8 Classification

All **Solution S5** stoves are classed as intermittent operation. There by meaning, to give nominal rated output, you will have to refuel a minimum of 45min for wood or 1hr for solid fuel, as stated in EN 13240:2011 +A2:2004.

7.9 Adverse weather conditions

If due to adverse weather conditions your stove does not operate correctly and causes the stove to emit smoke, do not treat it as a nuisance, this smoke will indicate that carbon monoxide is being emitted into the room. Extinguish the stove by reducing the firing rate, open windows and allow the stove's fuel to burn out before closing the windows. The probable cause is insufficient draw, check flue ways and have the chimney tested for flue pressure.

7.10 Door glass

The door glass should remain clear during normal burning. However under certain conditions, such as burning at a low or slow rate, using damp wood or overnight burning, the glass may become somewhat blackened. To remedy this, operate the appliance at a fast rate. Alternatively when the stove is cold, open the door and clean the inside face of the glass with a damp cloth or with glass cleaner.

7.11 Fire door handle

Care must be taken when opening and closing the fire door as any surrounding surfaces will be VERY HOT.



**ALWAYS USE THE HOT GLOVES WHEN USING THE FIRE DOOR / RIDDLE HANDLE— RISK OF PERSONAL INJURY MAY OCCUR.
CAUTION MUST BE GIVEN WHEN RE-FUELLING THE APPLIANCE, KEEP THE HOT GLOVE AWAY FROM NAKED FLAMES & SPARKS.**

8 Care for your stove

The need for regular maintenance on your stove will ensure, safe and efficient use of your appliance. The following item listing should be checked and inspected by a competent person or engineer on a regular basis.



PLEASE ENSURE THAT THE STOVE IS UNLIT AND COLD, BEFORE ATTEMPTING TO INSPECT THE BELOW ITEMS -

8.1 Adjusting the door hinges

Once the appliance has been under fire for a period of time the fire door may appear to have moved out of alignment with relation to the door aperture or catch. This is quite normal and due to the settling of the casting.

If the fire door needs to be raised, please follow the instructions below:

Open the fire door so that it is at right angles to the front of the stove.

Apply a lifting pressure to remove the door from the hinge assemblies, it may be necessary to move the door assembly from left to right whilst applying an upward force, to release the door from the hinges.

Drop one washer (M6) over the top hinge pin. Align the door assembly onto the hinge and apply a downward pressure to re-fit the door onto the hinge assemblies. Check & repeat again if necessary.

8.2 Liners / firebricks

The stoves liners (also known as firebricks) may become cracked after long periods of heavy use or after being knocked by the loading of fuel or a poorly aimed fire poker. If the liners are still staying in situ and are able to support themselves correctly there is no need to replace them. Cracked liners will not in themselves effect the performance of the stove.

8.3 Throat plate

The throat plate can be removed from the stove, by removing both the side liners, this will then allow the rear of the throat plate to swing down. Disengage the front lip of the throat plate from the upper location bracket. Rotate the throat plate, diagonally across the firebox, manipulating the plate through the door opening.

Any accumulated deposits should be cleaned off, this is best done with a brush.

Whilst doing so, inspect the throat plate for any damage.

Replacement throat plates can be sourced from your local dealer or via the internet at **www.aradastovesandspares.com**.

8.4 Fire door seal

The rope seal around the edges of the main fire door should also be checked. Look for signs of fraying, peeling away or the ends not meeting. If the rope is unable to create a good seal with the stove body it should be replaced. A poor seal will decrease your ability to control the burn rate and its efficiency whilst leading to an increase in heat lost through the flue.

8.5 Cracked glass

It is not recommended to operate the stove with cracked glass; this can lead to over firing due to air leaking into the firebox and it may fail completely leading to personal injury or a fire. You should discontinue use of your stove until it has been repaired. You can source replacement glass kits from www.aradastovesandspares.com or your local retailer.

8.6 Chimney / Flue Sweeping

Sweeping should be carried out with an appropriate sized bristle brush and rods to suit chimney size and type. As with all appliances regular sweeping of the flue / chimney is essential to avoid dangers of blockage and the escape of poisonous fumes. Access for cleaning should also be incorporated in the chimney (eg: soot door or access through the register plate etc).

It is important that the flue connections, flue pipe and chimney be cleaned prior to lighting after a prolonged period of non use.

9 Further resources / information

9.1 Information

- Competent Person Schemes
<https://www.gov.uk/guidance/competent-person-scheme-current-schemes-and-how-schemes-are-authorised>
- Document J Building Regulations (Combustion Appliances)
www.planningportal.gov.uk/
- The National Association of Chimney Sweeps (NACS)
www.nacs.org.uk/
- Smoke Control Areas—The Rules
www.gov.uk/smoke-control-area-rules
- Clearskies Guide (Independent Performance Certification Scheme)
www.clearskiesmark.org

9.2 Specification

All **Solution S5** stoves are manufactured and independently tested to EN standard 13240 and are CE marked. Within the above EN standard, material specifications and criteria are defined.

10 Guarantee

10.1 Guarantee

If any part of the main body of the stove fails due to a manufacturing or material defect during the guarantee period that applies in respect of the relevant stove (as set out below), **Hamlet Stoves** will, at its sole discretion, repair or replace your stove, for no charge.

For the purposes of this guarantee, a material or manufacturing defect includes the splitting or cracking of the main body (defined as the steel outer casing and items fixed immovably to the casing).

Damage caused by over-firing or over-heating is not covered. Warping and a red-oxide colouring will demonstrate the over- heating of internal parts; body paint which has turned dusty white is also indicative of such use.

The following guarantee periods shall apply in respect of the following :

Solution S5 stoves come with a **10 Year** warranty to the main body of the stove.

The external paint finish carries a one-year guarantee only.

This guarantee is subject to the Terms and Conditions set out below.

10.2 Terms and Conditions

The following terms and conditions must be satisfied in order for your stove to be covered by the guarantee set out above:

1. Your stove must have been purchased from an officially approved dealer.
2. You must be the original purchaser of the stove in order to make a claim. This guarantee is not valid in relation to any claims made by someone who did not originally purchase the stove from **Hamlet Stoves** or an approved retailer / dealer.
3. Any claim under this guarantee must be made through the approved dealer where the stove was purchased and accompanied by proof of purchase (e.g. a valid receipt). Stoves not purchased from an approved retailer / dealer will not be covered by this guarantee.
4. Your stove must be installed in the UK for this guarantee to be valid. Stoves installed outside of the UK will not be covered by this guarantee.
5. Your stove must have been installed by a suitably qualified person and in accordance with the manufacturer's installation instructions. Stoves not installed by a suitably qualified person or not installed in accordance with the manufacturer's installation instructions will not be covered by this guarantee.

6. Any claims under this guarantee shall not be valid where the installation of the stove does not conform to all required building regulations and other legislation in force at the time of purchase and where flue draw readings have not been made to confirm a suitability of the flue. The manufacturer's decision as to whether this condition has been satisfied shall be final.
7. The guarantee does not cover damage caused to the stove through careless handling or misuse or neglect of the appliance (misuse and neglect being not following the manufacturer's instructions and user guides in relation to the stoves, including the use of non-recommended fuels).
8. Consumable service items are not covered by this guarantee.
9. The guarantee does not cover damage caused by storing or using the stove in a damp environment, defects or faults caused by local conditions such as draught problems and chimney defects or corrosion caused by condensation, damp or water ingress into the flue, chimney or the surrounding of the stove.
10. The guarantee is only valid if the stove is serviced and checked annually by a suitably qualified heating engineer, with documentation to be retained and produced in the event of a claim being made.
11. The guarantee is only valid where any spare parts used are supplied by **Hamlet Stoves** or an approved retailer / dealer. The use of spares other than those supplied by **Hamlet Stoves** shall invalidate the guarantee. Parts can be purchased through an approved dealer or directly from **Arada Ltd**, online at www.aradastovesandspares.com
12. The guarantee is not valid where any repairs or modifications have been made to the stove which have been carried out by anyone other than **Hamlet Stoves** or its authorised representatives or approved dealers.
13. All guarantee periods commence on the date of purchase and are non-transferable and solely for the benefit of the original purchaser of the stove.

10.3 General

Our guarantee is offered as an addition to your statutory rights and will not effect your statutory rights. You can obtain information about your legal rights from trading standards office's or a citizens' advice bureau.

This guarantee is applicable in the UK only and operates exclusively in accordance with the laws of England and Wales.

If you believe your appliance is not working correctly or it has broken down, in the first instance please contact your local retailer or installer for assistance.

11. Recycling



11.1 Packaging recycling

The majority of the packaging components can be recycled, by material components:

- **WOOD** (Pallet) - Household quantities of wood waste can be taken to your local [Household Waste Recycling Centre](#).
- **CARDBOARD** (Outer packaging) - Most local councils will collect cardboard as part of their kerbside collection; Otherwise, cardboard can be recycled at your local [Household Waste Recycling Centre](#).
- **PLASTIC** (Internal bubble packing / bags / outer strapping) - Some district councils collect plastic packaging in their kerbside collections; Alternatively, most major supermarkets have plastic bag collections. The outer strapping should be taken to your local [Household Waste Recycling Centre](#).



11.2 End of life product recycling

Again like the packaging, the majority of the appliance components can be recycled by the material components:

- **CAST IRON & STEEL** : All metal components can be recycled at your local [Household Waste Recycling Centre](#).
- **GLASS** : Most local councils will collect glass as part of their household kerbside collection; Otherwise, glass can be recycled at your local [Household Waste Recycling Centre](#).
- **FIREBOX LINERS & GASKET/SEALS** : These components are not currently recyclable and should be disposed of at your local [Household Waste Recycling Centre](#).

Your local Household Waste Recycling Centre can be located :

<https://www.recyclenow.com/local-recycling?>

12. Technical Data

TECHNICAL DATA	Solution 4kW S5	Solution 5kW S5
Height (mm)	473 mm	551 mm
Width (mm) (Across Canopy & Riddle Boss)	334 mm	436 mm
Depth (mm) (Rear To Handle Boss)	387 mm	387 mm
Height To Centre Of Rear Flue (mm)	393.5 mm	448 mm
Depth From Back To Flue Centre (mm)	90 mm	82 mm
Flue Diameter –mm (Inch)	127 (5")	127 (5")
Minimum Distance To Combustible Materials & Maximum Hearth Temperature Single Walled Flue, <u>Without</u> Rear Heat Shield Fitted	650 mm (Rear) 650 mm (Side) 92 °C (Hearth)	750 mm (Rear) 550 mm (Side) 54 °C (Hearth)
Minimum Distance To Combustible Materials & Maximum Hearth Temperature Single Walled Flue, <u>With</u> Rear Heat Shield Fitted	375 mm* (Rear) 650 mm* (Side) 92 °C (Hearth)	500mm* (Rear) 550mm* (Side) 54 °C (Hearth)
Minimum Distance To Combustible Materials & Maximum Hearth Temperature Twin Walled Flue, <u>With</u> Rear Heat Shield Fitted	225 mm** (Rear) 650 mm** (Side) 92 °C (Hearth)	350mm** (Rear) 550mm** (Side) 58 °C (Hearth)
Weight Packed	62 Kg	77 kg
Weight Nett	58 Kg	68 Kg

IMPORTANT NOTE : */** See Section 11—Additional Information—Reduced Distances

TECHNICAL DATA	Solution 5 kW Widescreen S5	Solution 7 kW S5
Height (mm)	551 mm	551 mm
Width (mm) (Across Canopy & Riddle Boss)	518.5 mm	518.5 mm
Depth (mm) (Rear To Handle Boss)	387 mm	387 mm
Height To Centre Of Rear Flue (mm)	448 mm	448 mm
Depth From Back To Flue Centre (mm)	82 mm	82 mm
Flue Diameter –mm (Inch)	127 (5")	127 (5")
Minimum Distance To Combustible Materials & Maximum Hearth Temperature Single Walled Flue, <u>Without</u> Rear Heat Shield Fitted	900 mm (Rear) 550 mm (Side) 94 °C (Hearth)	650 mm (Rear) 650 mm (Side) 53 °C (Hearth)
Minimum Distance To Combustible Materials & Maximum Hearth Temperature Single Walled Flue, <u>With</u> Rear Heat Shield Fitted	450mm* (Rear) 550mm* (Side) 94 °C (Hearth)	500mm* (Rear) 900mm* (Side) 53 °C (Hearth)
Minimum Distance To Combustible Materials & Maximum Hearth Temperature Twin Walled Flue, <u>With</u> Rear Heat Shield Fitted	350mm** (Rear) 500mm** (Side) 94 °C (Hearth)	350mm** (Rear) 650mm** (Side) 53 °C (Hearth)
Weight Packed	98 Kg	93 Kg
Weight Nett	83 Kg	75 Kg

IMPORTANT NOTE : */** See Section 11—Additional Information—Reduced Distances

TECHNICAL DATA	Solution 4kW S5	Solution 5kW S5
Nominal Heat Output—Wood (Kw)	4.6	4.9
Efficiency Nett At Nominal Heat Output (%)	83.1	80.6
Mean Flue Gas Temperature (°C)	232	265
Mean CO Emission @ 13% O2 (%)	0.10	0.09
Flue Mass Gas Flow (g/s)	3.7	4.0
Typical Fuel Load To Achieve Nominal Rated Output Per Hour (Kwh/Kg) (Seasoned Hardwood)	0.94	1.10
Mean CH Emission @ 13% O2 (%)	91	67
Mean NOx Emission @ 13% O2 (%)	113	104
DIN Plus Particulates @ 13% O2 (%)	28	22
Ideal Log Length & Diameter (mm)	200 / 100	300 / 100
Nominal Heat Output—Solid fuel (Kw)	4.4	4.9
Efficiency Nett At Nominal Heat Output (%)	75.5	79.7
Mean Flue Gas Temperature (°C)	300	275
Mean CO Emission @ 13 % O2 (%)	0.11	0.11
Flue Mass Gas Flow (g/s)	3.8	3.8
Typical Fuel Load To Achieve Nominal Rated Output Per Hour (Kwh/Kg) (MSF Maxibrite)	0.70	0.75
Mean CH Emission @ 13% O2 (%)	45	44
Mean NOx Emission @ 13% O2 (%)	150	132
DIN Plus Particulates @ 13% O2 (%)	16	33

TECHNICAL DATA	Solution 5 kW Widescreen S5	Solution 7 kW S5
Nominal Heat Output—Wood (kW)	5.0	7.0
Efficiency Nett At Nominal Heat Output (%)	82.5	77.9
Mean Flue Gas Temperature (°C)	240	291
Mean CO Emission @ 13% O2 (%)	0.12	0.12
Flue Mass Gas Flow (g/s)	4.0	6.2
Typical Fuel Load To Achieve Nominal Rated Output Per Hour (Kwh/Kg) (Seasoned Hardwood)	1.17	1.55
Mean CH Emission @ 13% O2 (%)	113	107
Mean NOx Emission @ 13% O2(%)	84	109
DIN Plus Particulates @ 13% O2	13	18
Ideal Log Length & Diameter (mm)	330 / 100	330 / 100
Nominal Heat Output—Solid Fuel (kW)	5.0	7.1
Efficiency Nett At Nominal Heat Output (%)	79.4	81.5
Mean Flue Gas Temperature (°C)	291	326
Mean CO Emission @ 13% O2 (%)	0.05	0.06
Flue Mass Gas Flow (g/s)	3.3	4.3
Typical Fuel Load To Achieve Nominal Rated Output Per Hour (Kwh/Kg) (MSF Maxibrite)	0.73	1.0
Mean CH Emission @ 13% O2 (%)	30	42
Mean NOx Emission @ 13% O2 (%)	121	120
DIN Plus Particulates @ 13% O2 (%)	25	24

13. Additional Information

13.1 Reduced Distances To Combustibles

For installations, where the optional heat shield has been fitted to the appliance, reduced distances to combustible materials can be observed, as stated in the table on page 27 & 28 (Figures highlighted by *).

These reduced distances can be taken into account during installation, however, the minimum distances were ONLY achieved when using the optional rear heat shield and single walled flue pipe, fitted to the appliance.

13.2 Twin walled flue—Reduced Distances

For twin walled flue installations, reduced distances to combustible materials can be observed, as stated in the table on page 27 & 28 (Figures highlighted by **).

This information can also be found on the data label attached to the stove.

These reduced distances can be taken into account during installation, however, the minimum distances were ONLY achieved when using Arada specified twin wall starter section (Schiedel 5" (149644) & 6" (149645)) and when also the optional rear heat shield has been fitted to the appliance.

14. Optional Accessories

Optional accessories can be purchased from your supplying dealer or from the Arada web site, for the Solution S5 range, the following accessories are available :

- Rear Heat Shield
- Safety Handle
- Direct Air Connection (incorporated into rear heat shield)

AFFIX DUPLICATE STOVE DATA LABEL HERE



Hamlet is a brand name of Arada

Arada Ltd

The Fireworks,
Weycroft Avenue - Axminster- Devon
EX13 5HU
United Kingdom

www.aradastoves.com
T: +44 (0)1297 632 050

www.aradastovesandspares.com
Technical Helpline: +44(0)1297 632 052