

---

# Farringdon 16 Wood Stove

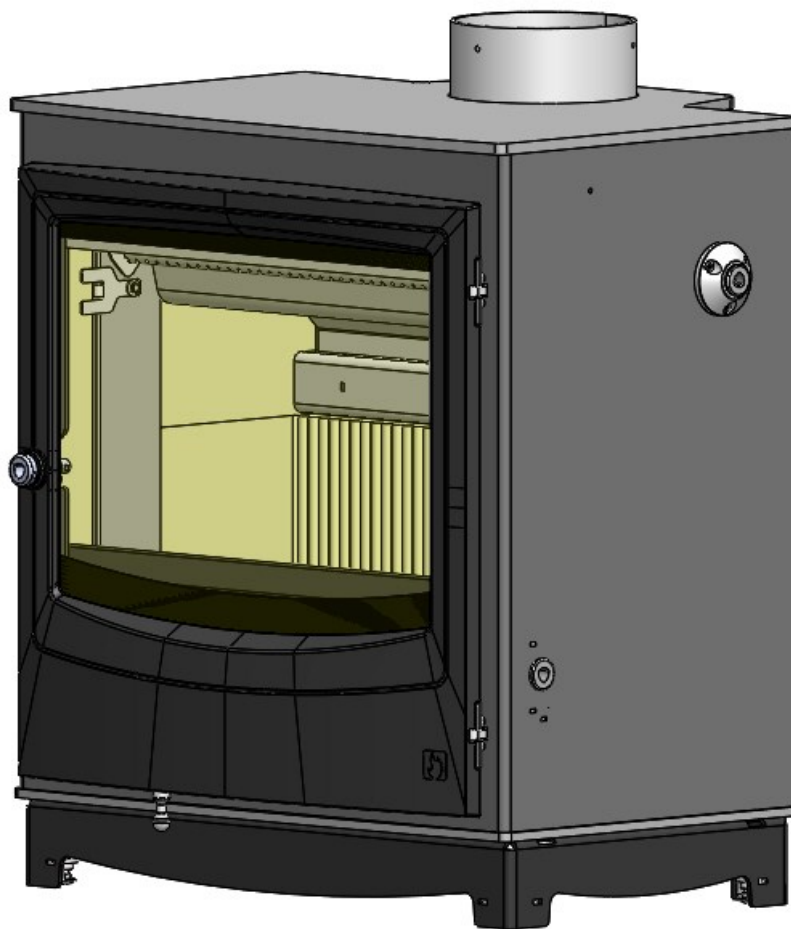



---

## **Congratulations on your choice of an Arada Stove.**

**Read all instructions carefully before installing your wood burning stove. If you are in any doubt about the instruction to install your appliance correctly, we suggest to call a professional master installer. A wrong installation may result with a fire, burns and possible death.**

**Keep these instructions.**

**This appliance must be connect to**

- **A HT type factory-built chimney approved UL103 or ULC 629 with a 6 inches dia. (15.24 cm)**
- **A code-approved masonry chimney with a flue liner with a 6 inches diameter (15.24cm)**

**N.B: Be warned that local codes and rules can have more specific requirements than those detailed in this manual.**

**You should consult a master installer, fire officials or local building office about restriction and installation inspection in your area and to determine if you need to obtain a permit Prior to installation.**

**Install and operate this stove only in accordance with these instruction  
Applicable standards: UL 1482-11, ULC S627-00**

**This manual describes the installation and operation of the Arada, Farrington 16 catalytic equipped wood heater. This heater meets the 2015 U.S. Environmental Protection Agency's crib wood emission limits for wood heaters sold after May 15, 2015. Under specific test conditions this heater has been shown to deliver heat at rates ranging from 8,000 to 55,000 Btu/hr 2.4 - 16kw/hr**

**This wood heater has a manufacturer-set minimum low burn rate that must not be altered. It is against federal regulations to alter this setting or otherwise operate this wood heater in a manner inconsistent with operating instructions in this manual.**

**This wood heater contains a catalytic combustor, which needs periodic inspection and replacement for proper operation. It is against federal regulations to operate this wood heater in a manner inconsistent with operating instructions in this manual, or if the catalytic element is deactivated or removed.**

**PLEASE RETAIN THIS GUIDE FOR FUTURE REFERENCE**

**We recommend our wood burning stoves be fitted by an installation engineer certified in the US by  
The National Fireplace Institute (NFI)  
And in Canada by the Wood Energy Technology (WETT)**

**PLEASE NOTE—** *Arada has a policy of continuous product development and therefore we reserve the right to amend the specification without prior notice.  
Due to printing cycles, items or options may be described before they are generally available or after they have ceased, so please check with your retailer or dealer.*

# Contents

---

	Page No.		Page No.
<b><u>INTRODUCTION</u></b>		<b><u>SERVICE &amp; MAINTENANCE</u></b>	
Warning Notice	4	Maintenance	23
Safety Notices	5	Cleaning	23
The Principle Of The Stove	5	Chimney Sweeping	23
Check List	6-7	Door Glass	23
Data Label Plate Information ( Plates A & B )	8-9	Outer Finish	23
Technical data	10	Fire Door Rope Replacement	24
<b><u>INSTALLATION</u></b>		Fire Door Glass Replacement	24-25
General Precautions	11	Service Record	26
Handling	11	<b><u>OPERATING INSTRUCTION</u></b>	
Hearth	11	Fuel Types	27
Combustible Materials	11	Fuel Storage	27
Air For Combustion	11	Lighting The Stove	27
Fitting The Flue Outlet & Hotplate	12	Burning Wood	28
Flues & Chimneys	13-16	Smoke Detectors	28
Floor protection, Distance to Combustibles	17-19	Over Firing & Chimney Fires	29
Firebox Liner Panels	20	Ash Removal	29
Catalyst replacement	21	Air Inlet Control	30
Final Check List	22	Catalyst and Bypass control	31
Summer Storage / Non Usage	22	Main Fire Door Handle	32
		Parts List	33
		<b>GUARANTEE ( USA &amp; Canada ONLY )</b>	34-35
		<b>A USER QUICK REFERENCE GUIDE ( ENGLISH AND FRENCH )</b>	36-37
		Additional information on the correct Function of catalyst within this stove	38
		<b>FACTORY CHECK LIST</b>	39

---

---

# WARNING

**THIS STOVE MUST NOT BE CONNECTED  
TO A SHARED FLUE SYSTEM SERVING ANOTHER APPLIANCE**

**TO ALL USERS  
THIS APPLIANCE IS SUITABLE FOR WOOD BURNING ONLY**

**ANY FORM OF COAL  
SHOULD NEVER BE USED IN YOUR STOVE**

**TO USE ANY FUEL OTHER THAN WOOD WILL INVALIDATE  
THE APPLIANCE GUARANTEE.**

**THIS APPLIANCE IS NOT SUITABLE FOR USE IN A MOBILE HOME**

**DO NOT CONNECT OR USE IN CONJUNCTION WITH ANY AIR  
DISTRIBUTION DUCTWORK UNLESS SPECIFICALLY APPROVED FOR  
SUCH INSTALLATIONS**

**DO NOT USE CHEMICALS OR FLUIDS TO START THE FIRE  
DO NOT CONNECT THIS STOVE TO A CHIMNEY FLUE SERVING ANOTHER APPLIANCE**

**Installation of wood burning stoves must be safe and legal.  
The Farrington 16 is designed for installation in main living areas of your home only.**

If your Farrington stove is not installed correctly, it may cause a house fire.  
To reduce the risk of fire, the installation instructions must be followed carefully.  
Do not allow makeshift compromises to endanger property and personal safety. Contact  
the local building officials about restrictions and installation inspection in your area.

Under no circumstances make impromptu alterations or modifications to this stove.  
It is an approved appliance and changes to the product or tampering with the design will render it  
**non-compliant**

This also applies to 'ad hoc' repairs using non Arada approved components

**FOR FURTHER INFORMATION,  
REFER TO THE NATIONAL FIRE PROTECTION ASSOCIATION  
ANSI/NFPA 211 STANDARD FOR CHIMNEYS, FIREPLACES, VENTS AND  
SOLID FUEL BURNING APPLIANCES.**

---

### SAFETY

A fireguard should be used in the presence of children and elderly or infirm people. Please note, This appliance should be used with the fire door closed at all times except when re-fuelling or de-ashing.

**REMEMBER THE STOVE IS VERY HOT DURING OPERATION. KEEP CHILDREN, CLOTHING AND FURNITURE AWAY. CONTACT MAY CAUSE SKIN BURNS.**

**Do not use aerosol sprays or any other flammable materials near the appliance under fire.**

**Do not fit an extractor fan in the same room as the appliance.**

**Fire cement is caustic, hand and eye protection should always be worn, prolonged contact with the skin should be avoided.**

**Arada Ltd will not be responsible for any consequential or incidental loss or injury however caused.**

Before continuing any further, with the installation of this appliance please read the following guide to manual handling.

- Always obtain assistance when lifting the appliance
- When lifting always keep your back straight, bend your legs not your back
- Avoid twisting at the waist. It is better to reposition your feet.
- Avoid upper body/top heavy bending. Do not lean forwards or sideways when handling the fire
- Always grip with the palms of your hands do not use your fingertips for support
- Always keep the stove as close to the body as possible as this will minimise the cantilever action.
- Use gloves to provide additional grip.

### THE PRINCIPLE OF THE STOVE

Your **Arada** stove is built to the highest standard of craftsmanship using the best materials and the most modern equipment available. It is a highly efficient and sophisticated piece of machinery and when properly installed and operated should provide a lifetime of heating satisfaction.

Safety is the most important consideration when installing your fire. If not properly installed and operated a house fire may result. Installation must comply with the Building Regulations and conform to all safety standards.

**Arada** produce a variety of appliances ranging from the traditional to the modern in style and appearance.

The fire door is fitted with a special high temperature ceramic glass panel through which the fire can be viewed.

The stove is lined with firebricks or heat reflective panels which ensure complete combustion and provide a good heat store to even out fluctuations in burning.

An internal throat plate produces turbulence to encourage secondary combustion and direct the flue gas around the whole upper firebox before allowing it to escape up the chimney.

#### Grate Bars





The **Farrington 16** wood stove is fitted with a riddling grate system to support the fuel above the ash pit containing the removable ash pan.

**The stove is designed to burn wood only on the grate and the stove MUST NOT be used without the grate fitted. Spare grate bars are available see page 28 for part number details**



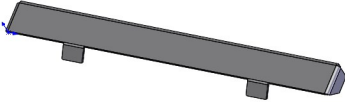
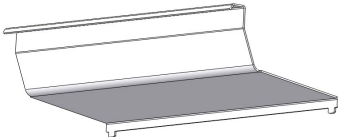



**Arada** stoves are also fitted with an 'air wash' so called because it provides a curtain of high speed preheated air behind the glass to help keep it clean and provide secondary air/over draught.

# CHECK LIST

Inside the appliance body you should find the following:

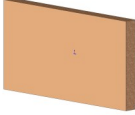
Part Description & Visual Aid (not to scale)	Farrington 16
<b>1. Fuel Retainer</b> 	1
<b>2. Throat Plate</b> 	1
<b>3. Ash Pan</b> 	1
<b>4. Throat Plate Insulation Blanket</b> 	1
<b>5. Instruction Manual</b> 	1

**Inside the appliance you should find the following :**

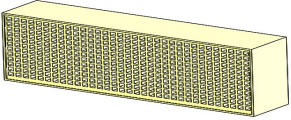
Description & Visual Aid (not to scale)	Farringdon 16
<b>6. Back Side Liners</b> 	<p style="text-align: center;"><b>4</b></p>
<b>7. Front Side Liners</b> 	<p style="text-align: center;"><b>2</b></p>
<b>8. Rear Liner</b> 	<p style="text-align: center;"><b>2</b></p>
<b>9. Grate Bars</b> 	<p style="text-align: center;"><b>12</b></p>
<b>10. Stove Mitten ( Hot Glove)</b> 	<p style="text-align: center;"><b>2</b></p>
<b>11. Fire Door and grate riddling Handle</b> 	<p style="text-align: center;"><b>1</b></p>
<b>12. Ceramic Catalyst</b> 	<p style="text-align: center;"><b>1</b></p>

# DATA LABEL PLATES

## Farringdon 16 Safety Label A

This Stove data label is manufactured from plated mild steel, laser etched with the information detailed below. and is permanently fixed to the top of the stove heat shield

CONTACT YOUR LOCAL BUILDING OFFICIAL ABOUT RESTRICTIONS AND INSTALLATION INSPECTION IN YOUR AREA

CONTACTER VOTRE RESPONSABLE D'INSTALLATION LOCAL POUR CONNAITRE LES RESTRICTIONS ET INSPECTIONS DES INSTALLATIONS DANS VOTRE REGION



**Listed Room Heater. Wood Fuel type, Poêle à bois homologué**

**Not suitable for use in a Mobile Home**

**Ne pas utiliser dans les maisons mobiles**

Manufactured by, Fabrique par Arada Ltd  
Axminster, Devon  
United Kingdom EX13 5HU

Serial #, No. de serie

Model Name, Modele

Tested To, Mis à l'épreuve selon la norme:-  
UL1482-11, ULC S627-00

**\* PREVENT HOUSE FIRES\* \* EVITER LES INCENDIES\***

Install and use only in accordance with manufacturers installation instructions and your local building codes  
Installer et utiliser seulement conformément aux instructions du fabricant et aux normes d'installation dans votre region

**Caution:** Special methods are required when passing chimney through a wall or ceiling, refer to local building codes. Do not connect this stove to a chimney serving another appliance.

**Attention:** Des procedes speciaux doivent etre employes pour passer un conduit de cheminee au travers de murs ou de plafonds. Referez-vous aux normes d'installation de votre region. Ne pas brancher cet appareil sur une cheminee servant a un autre appareil.

**Note:** Replace glass only with 5mm minimum Ceramic IR or Neoceram IR glass

**Remarque:** Remplacer la vitre seulement avec un verre Ceramic IR ou Neoceram IR de 5mm d'epaisseur

**Warning:** This unit is not suitable for use in a Mobile Home

**Attention:** Ne pas utiliser dans les maisons mobiles

**Inspect and clean the chimney frequently.**

**Under certain conditions of use, creosote buildup can occur RAPIDLY.**

**Inspecter et nettoyer la cheminee regulierement. Dans certaines conditions d'utilisation, la creosote peut s'accumuler rapidement**

### WARNINGS - ATTENTION

Do **NOT** burn with the grate system removed  
**Ne pas** utiliser sans la grille

Do **NOT** overfire. If the chimney connector glows you are overfiring. (See Manual)  
**Ne pas** surchauffer. Si le collet de la cheminee devient rouge. Le poele surchauffe (Voir notice d'utilisation)

Do **NOT** obstruct the space under the heater  
**Ne Rien** entreposer sous le poele

Do **NOT** connect this unit to a chimney serving another appliance  
**Ne pas** brancher cet appareil sur une cheminee servant a un autre appareil

Do **NOT** burn fuel **OTHER THAN WOOD** as this will damage the catalyst and will render it inactive

**Ne pas** brûler d'autre combustible que du bois car cela endommagerait le catalyseur et le rendrait inactive

The Combustor is fragile and must be handled carefully.  
L'ensemble comprenant catalyseur est fragile et doit être manipulé avec soin.

Replacement catalyst part No. **CatFAR16.01**  
Piece de rechange pour le catalyseur No. **CatFAR16.01**

This stove is only to be operated with the door **CLOSED**  
Le poele doit etre utilise porte **FERMEE**



### Caution - Attention:

**THE STOVE IS VERY HOT DURING OPERATION. DO NOT TOUCH, KEEP CHILDREN, CLOTHING AND FURNITURE AWAY. CONTACT WITH SKIN BURNS. SEE NAMEPLATE AND INSTRUCTIONS.**

**LE POELE EST TRES CHAUD PENDANT L'UTILISATION. NE PAS TOUCHER, GARDER LES ENFANTS, TISSUS ET MEUBLES A DISTANCE. LE CONTACT AVEC LA PEAU CAUSE BRULURES. VOIR LA PLAQUE SIGNALETIQUE ET LES INSTRUCTIONS.**

Minimum Clearance to Combustible Materials\*, Degagement minimum aux materiaux combustibles\*

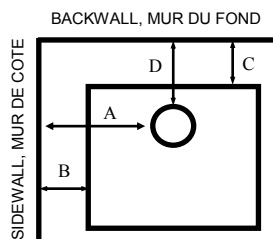

A = 27" / 686mm  
B = 18" / 457mm  
C = 17" / 432mm  
D = 14" / 356mm

When installed on a combustible floor, Non-combustible floor protection is required to cover the area beneath the stove, and extend at least 18" (458mm) to the front and 8" (203mm) to the sides and back.

Si le poele est installe sur un sol combustible, alors un protege plancher incombustible doit etre utilise pour couvrir la surface sous le poele et doit s'etendre au moins 18" (458mm) a l'avant et 8" (203mm) sur les cotes et a l'arriere.

**VENT REQUIREMENTS:**  
6" (150mm) diameter, single wall,  
Minimum 24 MSG blue steel connector with  
Listed factory-built Type HT chimney or  
masonry chimney.

\* Refer to the Installation manual for additional clearance information, Installation instructions and Operating instructions.

Se referer a la notice d'utilisation pour des informations complementaires sur les degagements, les instructions pour l'installation et l'utilisation.

**CARACTERISTIQUES POUR LES CONDUITS**  
Raccord en acier bleu minimum 24MSG de  
6" (150mm) paroi simple, avec une cheminee en  
acier fabrique en usine homologue de type HT ou  
une cheminee de maconnerie.

U.S. ENVIRONMENTAL PROTECTION AGENCY

Certified to comply with xxx, 2015 particulate emissions standards

AGENCE U.S. POUR LA PROTECTION DE L'ENVIRONNEMENT

Certifie conforme a xxx, norme d' emission de particules

### Date of Manufacture, Date de Fabrication

2017	2018	2019	2020	2021	2022	2023	2024	2025	2026	Jan	Feb	Mar	Apr	May	Jun	Jul	Aug	Sept	Oct	Nov	Dec	

DO NOT REMOVE THIS LABEL, NE PAS RETIRER CETTE PLAQUE SIGNALETIQUE

Made in England, Fabrique en Angleterre

# DATA LABEL PLATES

## Farrington 16 Safety Label B

This Stove data label is manufactured from plated mild steel, laser etched with the information detailed below.



Manufactured by, Fabrique par Arada Ltd  
Axminster, Devon  
United Kingdom EX13 5HU

Serial #, No. de serie

Model Name, Modele

Tested To, Mis a l'epreuve selon la norme:-  
UL1482-11, ULC S627-00

**U.S ENVIRONMENTAL PROTECTION AGENCY** Certified to comply with 2020 particulate emission standards using crib wood.  
This wood heater needs periodic inspection and repair for proper operation, consult the owners manual for further information. It is against federal regulations to operate this wood heater in a manner inconsistent with the operating instructions in the owners manual.

**Note:**  
The performance of the catalytic device fitted into this stove, or its durability has not been evaluated as part of the EPA certification.

### Floor Protection material R Values

Thermal protection of R Value 1.49 is required 16 inches (406mm) in front of the stove when installed directly onto the floor or a step lower than 7 inches (178mm) See diagrams below

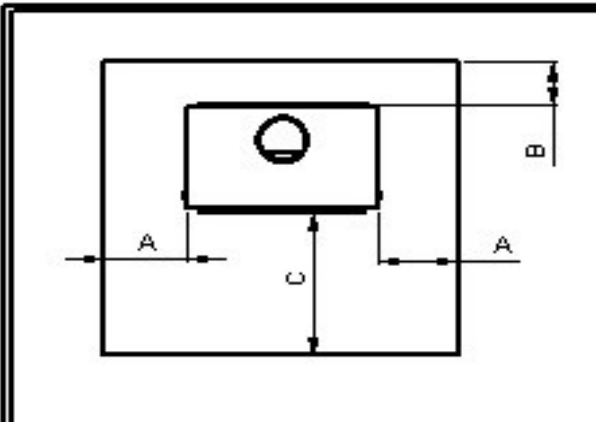

A	B	C (USA)	D (Canada)
203mm	203mm	406mm	458mm
8ins.	8ins.	16ins.	18ins.

Without 7 inch (178mm) Step

With 7 inch (178mm) Step

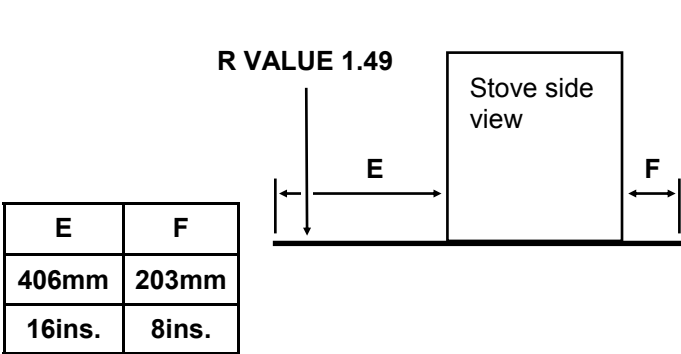

E	F
406mm	203mm
16ins.	8ins.

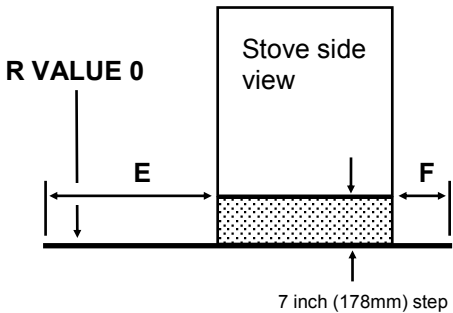

## TECHNICAL DATA

---

<b>TECHNICAL DATA</b>	<b>Farringdon 16</b>
<b>Maximum / Nominal Heat Output Kw</b>	<b>16</b>
<b>Mean Flue Gas Temperature °C</b>	<b>342</b>
<b>Height mm/inch</b>	<b>659/26</b>
<b>Width mm/inch</b>	<b>533/21</b>
<b>Depth mm/inch ( handle removed )</b>	<b>330/13</b>
<b>Flue Diameter mm/inch</b>	<b>152/6</b>
<b>Weight Packed Kg/lbs</b>	<b>84/185</b>
<b>Weight Nett Kg/lbs</b>	<b>78/172</b>
<b>Maximum / Ideal Log Length inch</b>	<b>17/16</b>
<b>Firebox size Cu. Inch / foot</b>	<b>2300/1.3</b>
<b>EPA Certified Emissions, grams per hour</b>	<b>1.5</b>
<b>HHV Tested Efficiency 1</b>	<b>77.2</b>
<b>EPA BTU</b>	<b>27000</b>
<b>Peak BTU/Hr</b>	<b>54,000</b>
<b>Fuel</b>	<b>Seasoned Cord wood</b>

## GENERAL PRECAUTIONS

**Note :** All local regulations, including those referring to National standards need to be complied with, when installing the appliance.

***Any Manufacturer's Instructions must not be taken as overriding statutory requirements.***

***Before any installation work is undertaken consideration must be given to the Health and Safety . Safe working practices should be followed at all times.***

During installation ensure that adequate precautions are taken to avoid unnecessary risk to yourself or any householder. In particular the danger from caustic nature of the fire cement should be avoided by using these accepted methods :

- Wear gloves when handling fire cement
- Wear goggles when chiselling or looking up chimneys.

Make sure that Building Regulations are adhered to during installation along with any local by-laws. In the case of heating systems make sure that the pipe work is correctly bonded to ensure electrical earth continuity.

## ASBESTOS

All Arada stoves contain no asbestos in their manufacture or construction. If there is a possibility of disturbing any asbestos in the course of installation, then please seek specialist guidance and use appropriate protective equipment.

## HANDLING

The safe handling guidelines are set out on page 5 of this manual, to make movement easier, internal fittings, fuel retainers, grates, firebox liners, flue outlets, hot plates, throat plates etc, can be removed. Care should be taken to make sure that the hinges are not damaged during installation.

## HEARTH

The stove shall be installed on a floor with adequate load bearing capacity. If the existing construction does not meet this prerequisite, suitable measures (e.g.: load distributing plate) should be taken to achieve it.

Ideally, the appliance should stand on a constructional hearth of non-combustible materials not less than 125mm (5") thick conforming to Building Regulations.

Dimensions of the hearth should project at least 458mm (18") forward of the front of the appliance and 203mm (8") at the sides.

The surface of the hearth should be free of combustible materials. In most buildings with solid concrete or stone floors, the requirement will be met by the floor itself, but mark the hearth to ensure floor coverings are kept well away or use different levels to mark the hearth perimeter.

## COMBUSTIBLE MATERIALS

Please view the technical data (See page 9) and observe the **minimum** distance to combustible materials, which is applicable to your stove model. Ideally, adjacent walls should be of suitable non combustible construction, preferably brickwork. In large fireplaces take care that any supporting beam is protected by a 13mm (0.5") sheet of Fire proof board spaced 13mm (0.5") off the surface with strips of non combustible material. Make sure that there is a gap between an un-insulated flue system and any combustible material. This gap must be at least 3X the outside diameter of the flue pipe, or 1.5X the flue diameter to non combustible surfaces.

## AIR FOR COMBUSTION

There must always be a permanent means of providing air for combustion into the room in which the stove is installed. Failure to provide an adequate air supply can result in the stove smoking back into the room and poor draw on the chimney. A permanent vent with a total free area of at least 550mm<sup>2</sup> for every KW rated above 5KW should be connected directly to the outside air or to an adjacent room which itself has a permanent vent of the same size direct to the outside air. The positioning of any air vent must be so that it cannot be liable to blockage or obstruction. **Please note :** The fitting of an extractor fan to either of these rooms is not recommended.

## INSTALLATION

### FITTING THE FLUE OUTLET AND HOT PLATE (Where Provided)

#### Note:

**Not applicable for units supplied with a fixed flue outlet spigot**

The flue outlet spigot is found packed inside the appliance. The hot plate (blanking plate) is supplied fitted to the top opening and is removed by turning clockwise (as is the flue outlet).

Smear a very thin layer of fire cement on the mating faces of the flue outlet and the hot plate. Fit the outlet to the appliance in the desired position.

Lock into place by rotating anti-clockwise and tighten by tapping with a block of wood and mallet from inside of the appliance. Similarly, fit the hot plate (blanking plate) to the unused opening. Clean off any surplus fire cement.

Place appliance on the hearth and make sure that it is level and does not rock.

Connect the chimney ensuring all joints are sealed with fire cement.

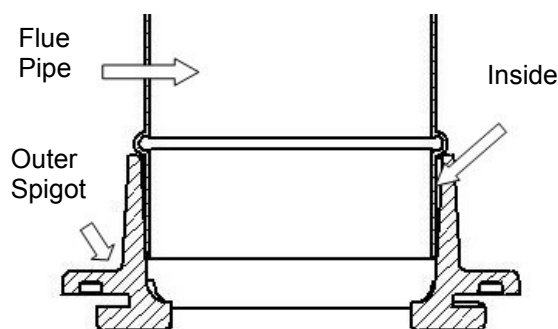

Fig. 1. Flue & Spigot Fitting

#### Important note :

##### For fixed and removable flue spigot types:-

The flue pipe **must** be fitted **inside** the outlet spigot. Failure to do so could result in the spillage of condensation and combustion residues running down the flue onto the stove canopy. (See Fig. 1)

### The chimney connector must be in good condition and kept clean

#### Chimney Connector:

The Chimney connector must be 6 inches diameter and have a minimum thickness of 24 gauge (0.025 inches 0.64 mm)

This must be secured into the flue spigot with 3 screws through the holes provided.

### FLUES AND CHIMNEYS

The flue draw is critical on any installation and should be checked to ensure that it matches what is specified. If it is higher than recommended, provision must be made to correct the over draw. The draw can vary in different weather conditions and the customer should be made aware of this. Failure to correct an over-drawing flue will invalidate the warranty.

Please remember that chimney draught is dependent on four main factors :

- Flue gas temperature
- Flue height
- Flue size
- Flue terminal

The stove must be connected to a suitable and efficient flue so that products of combustion (fumes) from the stove are expelled to the outside air. To ensure a good up draught it is important that the flue gases are kept warm and that the flue size suits the stove. The termination of the outlet at the top of the flue also needs to comply with Local Building Codes.

The minimum effective height of the flue should be at least 15 feet from the top of the stove to the top of the flue outlet. When warm the flue draught should be between 0.1 to 0.2 mb. (1-2 " H<sub>2</sub>O) A chimney may comply with regulations but could still be subject to down draught and similar problems. A chimney terminating above the ridge level is generally less likely to suffer such problems.

Excessive flue draught may cause over firing, See page 29, and very low flue draught (below 1" H<sub>2</sub>O) will result in poor combustion and greatly reduced heat output, and may prevent the stove reaching catalyst light-off temperature. Low draught can also cause the appliance to leak smoke into the room, and may cause the catalyst to become blocked

If a new chimney is being provided it should fully comply with the relevant Building Regulations that specify the requirements for solid fuel burning installations. Suitable types of chimney include the following :

#### Masonry Chimney:

A code-approved masonry chimney with a flue liner with a 6 inches diameter (15.24cm)

#### Factory Made Chimney:

A HT type factory-built chimney approved UL103 or ULC 629 with 6 inches diameter (15.24 cm)

The flue and chimney installation must be carefully checked by a competent person before fitting the stove to ensure it is suitable and will work safely.

If the chimney is old (ie: built of brick or stone without a liner) or being opened up for reuse additional checks and smoke testing should also be carried out to ensure the flue and chimney are good operating condition.

Check the existing flue is in good condition with suitable access for collection and removal of debris. If the flue size is more than 225mm (9") diameter or 200mm (8") X 200mm (8") square, a suitable lining of 150mm (6") diameter should be fitted, or if the flue length is over 5.5 metres one size larger than the appliance outlet should be fitted. This should be a double skin stainless steel flexible liner that is independently certified for use with solid fuel.

It is also important that suitable flue pipe is used to connect the stove to the flue in the chimney and that suitable access is provided into the flue for regular inspection and sweeping of the flue ways.

The installer should comply with regulation requirements in respect of providing a Notice Plate giving details on the chimney, flue lining, hearth and fireplace installation. Chimneys should be as straight as possible.

Horizontal runs should be avoided except where the rear outlet of the appliance ( if available ) is used, in which case the horizontal section should not exceed 150mm (6") in length.

**WARNING:** When wood is burnt slowly in a closed appliance it produces moisture , tar and Creosote which will create condensation and deposits in the chimney.

This effect can be minimised by burning hard for a short period, about 20 minutes, twice a day.

It is usually convenient to do this morning and night.

**Note: To avoid chimney problems your fire should not be burnt slowly for longer than 12 hours without a period of fast burning.**

**Inspection is advised on a regular basis and accumulations of more than 3mm removed.**

If the stove appears to be working hard but produces very little output to the room it is likely that excess draw is present in the chimney, and that heat is being sucked out of the appliance and up the chimney.

### Important Note:

**The chimney connector must not pass through an attic or roof space, closet or similar concealed space, or a floor, or ceiling. Where passage through a wall or partition of combustible constriction is desired the installation shall conform to CAN/CSA-B365, Installation code for Solid Fuel Burning appliances and equipment**

### Carbon Monoxide:

A damaged or leaking Flue or Chimney may allow products of combustion to enter the living area, we would recommend a **Carbon Monoxide Detector** be fitted for this reason.

Carbon monoxide is a highly toxic gas and can be dangerous in even very small quantities symptoms include headache, dizziness and nausea, if you experience any of these symptoms when using your wood stove **Open all the windows, and leave the room at once and seek expert advice**

## DO NOT CONNECT THIS STOVE TO A CHIMNEY FLUE SERVING ANOTHER APPLIANCE

### FOR ALL APPLIANCES

Access for cleaning the flue should be incorporated in the system other than through the appliance (e.g. A soot door or access through the register plate). Purpose made soot doors and inspection lengths are available from manufacturers of all systems. Ensure that the whole length of the flue can be reached from the soot door.

**Note: if the appliance is fitted with a draught stabiliser or if one is fitted to the flue pipe or chimney in the same room as the appliance, then the permanent air entry opening (or Openings) should be increased by 300 mm<sup>2</sup> for each KW of rated output.**

# INSTALLATION

---

## Typical Factory built chimney installation in a single family residence

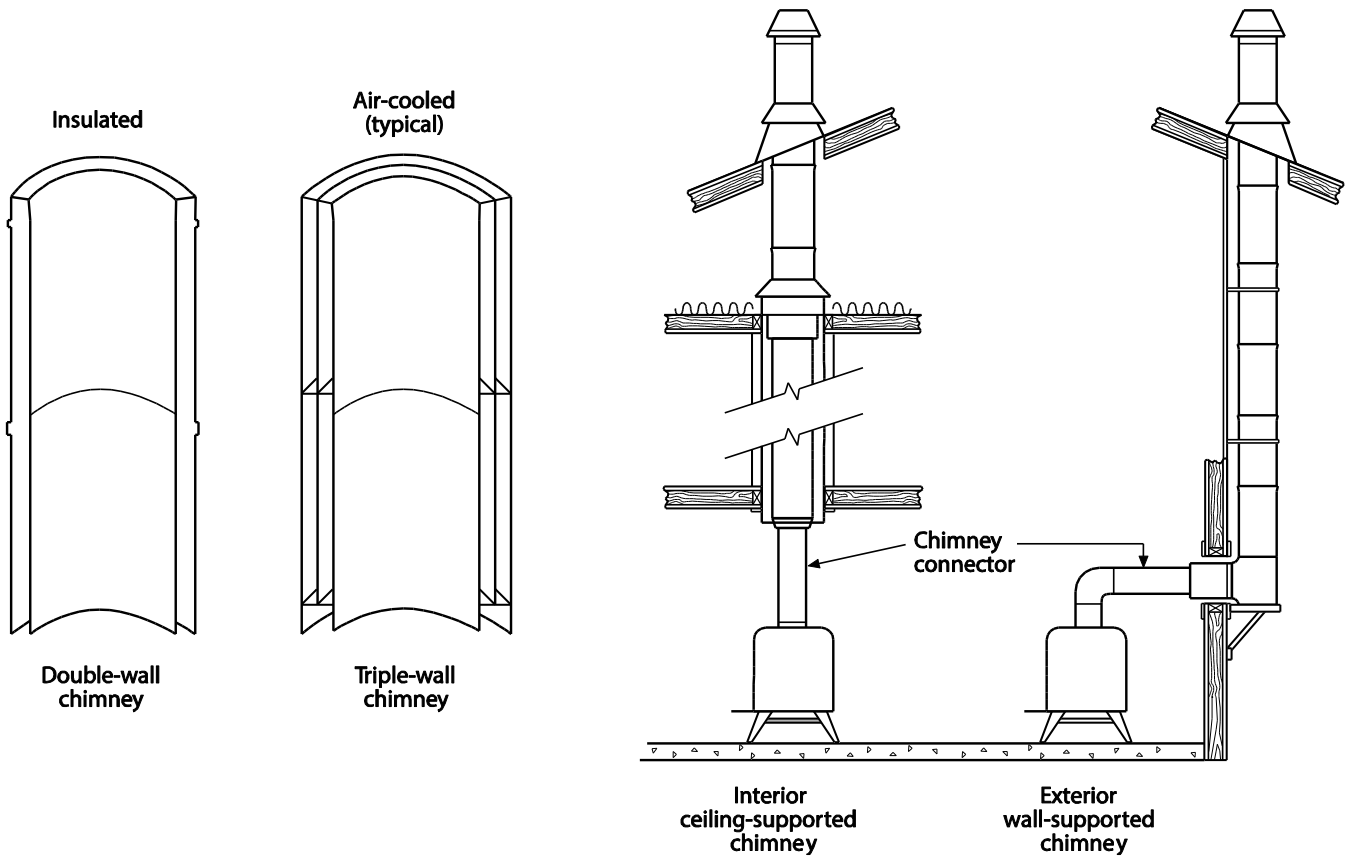

### General.

Factory built chimneys and chimney units must be installed in accordance with the temperature and pressure conditions detailed in the manufacturers instructions.

### Temperature and pressure limits.

Flue gas temperature and static pressure within the chimney must not exceed the limits used during listing tests

# INSTALLATION

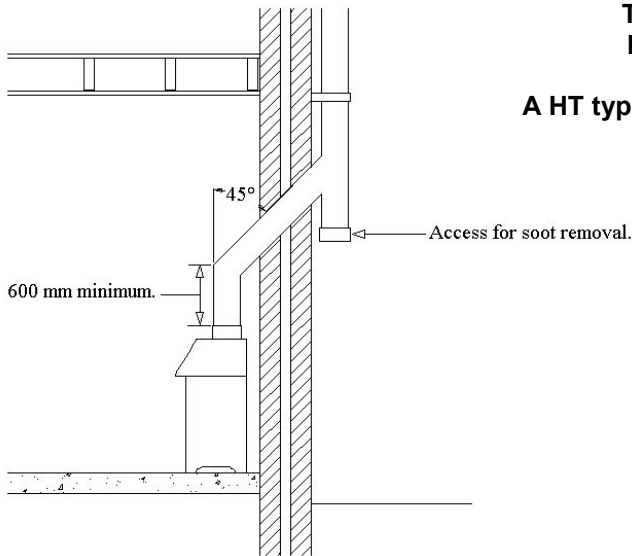

**Typical Metal Insulated Chimney System  
Installed To The Chimney Manufactures  
Instructions**  
A HT type factory-built chimney approved UL103 or ULC  
629 with 6 inches diameter (15.24 cm)

**A code-approved masonry chimney  
with a flue liner with a 6 inches  
diameter (15.24cm)**

## PLAN VIEW OF REGISTER PLATE AND CLEARANCES FOR NON INSULATED FLUES

(Plan View Of Steel Register Plate, 1.5mm Thick  
Minimum )

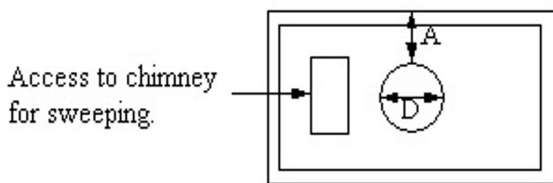

A (Minimum clearance for non-insulated flue) =  
1.5 x D to a non-combustible surface/material  
or  
3 x D to a combustible surface/material

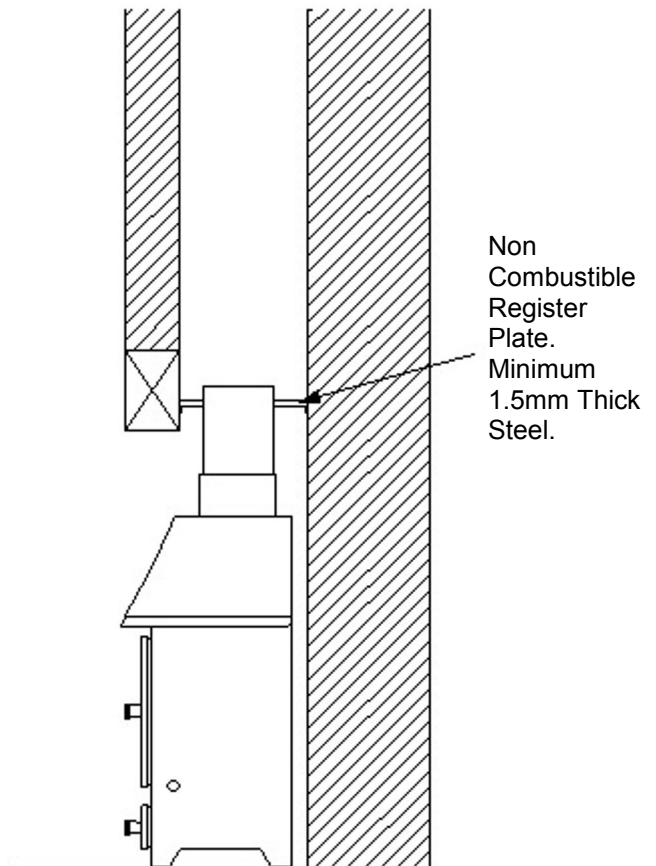

## INSTALLATION

---

### Masonry Chimney

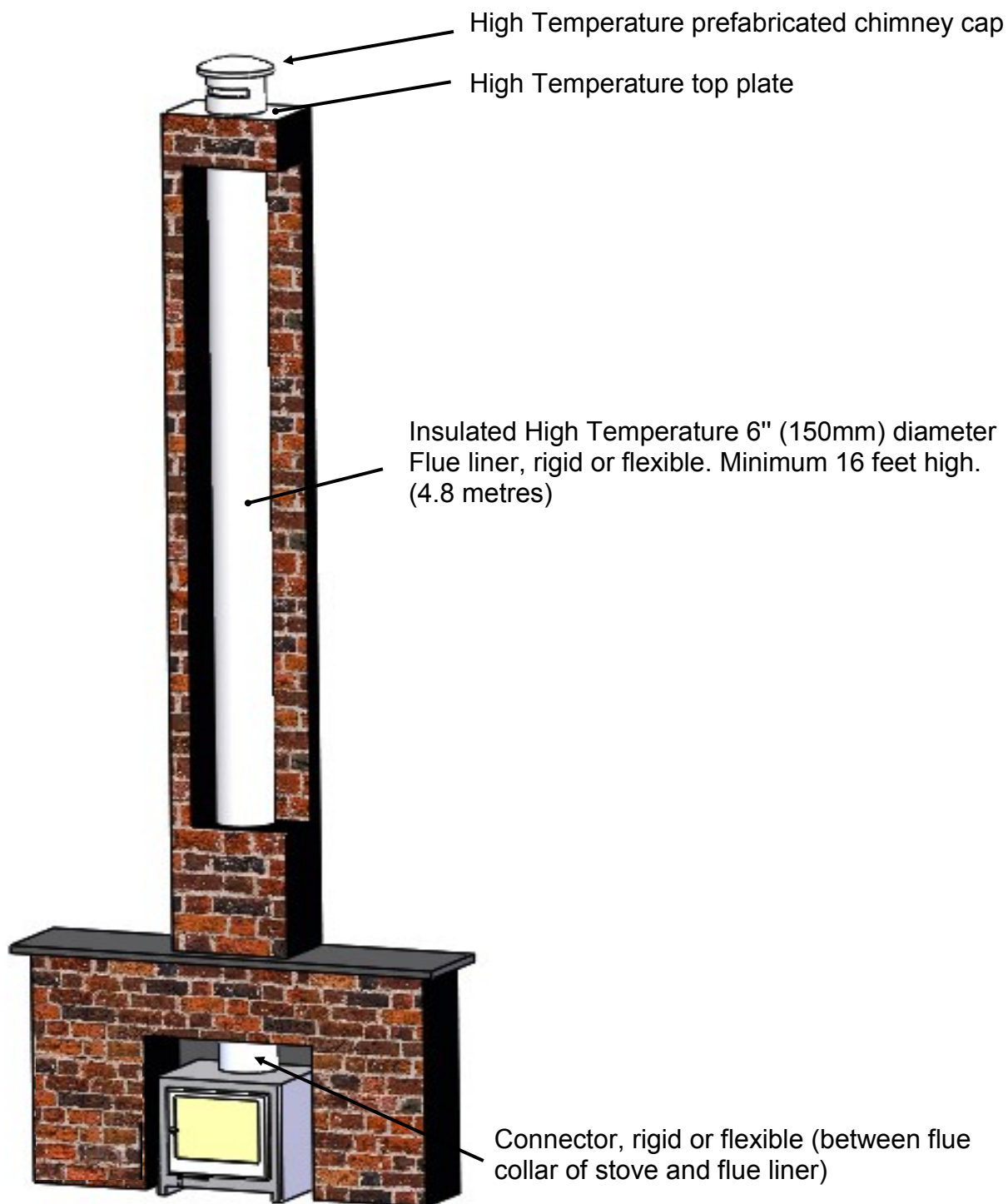

Sample installation into existing chimney.  
Chimney liner system has to be UL listed to UL 1777 in USA and ULC S635 in Canada.

### Floor Protection

The stove must be installed on a non-combustible material plate to protect the floor and possible fire caused by

- Ejection of sparks and hot ashes when the stove door is opened for refuelling etc.
- Radiated heat caused by stove over firing
- Spillage of creosote as a result of a chimney fire

The surface used must be non-combustible and approved to UL 1618 for USA or local codes  
( cement, brick, stone, ceramic etc )

# INSTALLATION

## Stove clearances on floor protection plate

The floor protection plate must be of Non-Combustible Material

Minimum dimensions listed may be increased

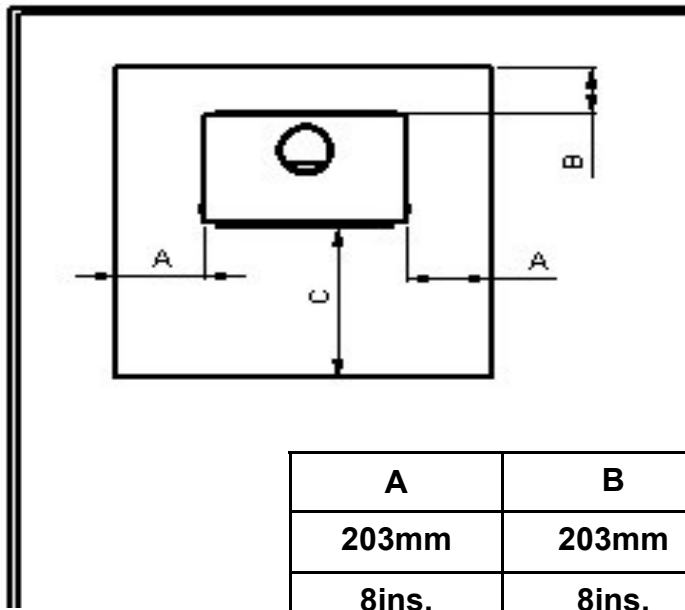

A	B	C (USA)	D (Canada)
203mm	203mm	406mm	458mm
8ins.	8ins.	16ins.	18ins.

## Floor Protection material R Values

Thermal protection of R Value 1.49 is required 16 inches (406mm) in front of the stove when installed directly onto the floor or a step lower than 7 inches (178mm) See diagrams below

### Without 7 inch (178mm) Step

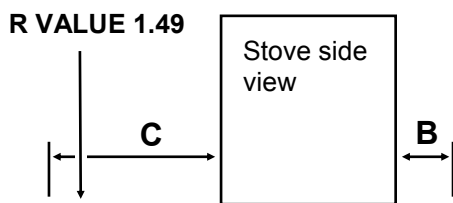

### With 7 inch (178mm) Step

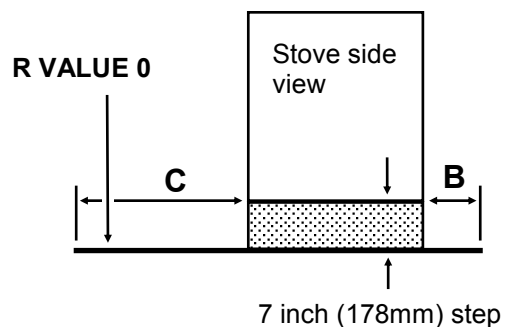

**Stove clearances to combustible material.**

Minimum dimensions listed may be increased. **Clearances may only be reduced by means approved by the regulatory authority.**

**Straight Installation clearances**

A	B	C	D
685mm	457mm	432mm	356mm
27ins.	18ins.	17ins.	14ins.

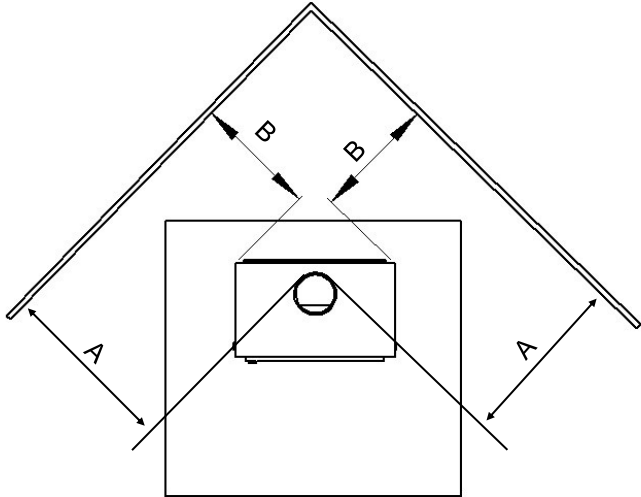
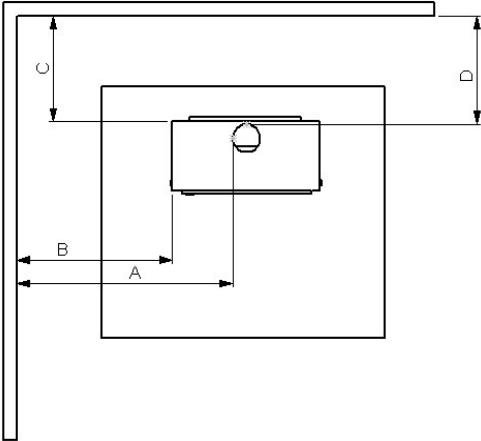

**Corner Installation clearances**

A	B
445mm	305mm
17.5ins.	12ins.

**Alcove Installation**

**Minimum distances**

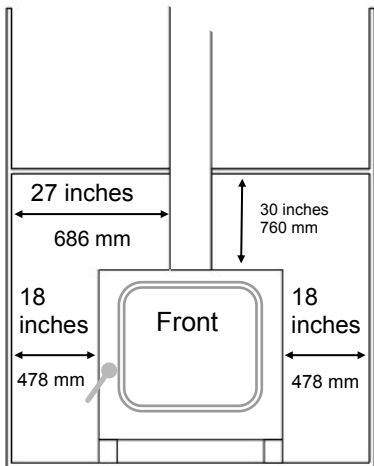
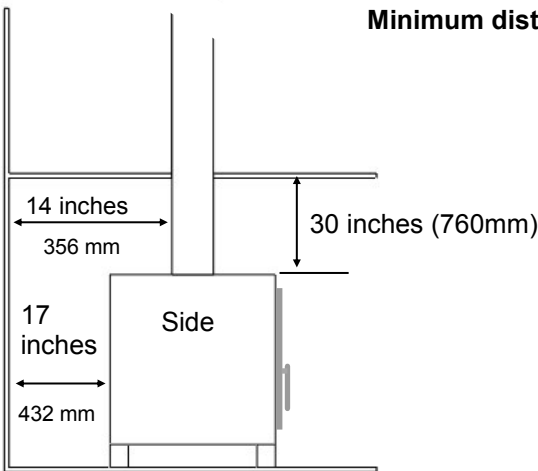

**Do NOT** connect this unit to a chimney serving another appliance

# INSTALLATION

## FIREBOX LINER PANELS

The Arada Farringdon stove uses firebox liner panels to the sides and back. The throat plate sits on top of the perforated air tube at the front and into two slots in the rear air bar. These parts should come fitted to your stove, if however they are not, proceed as follows to fit them.

- Open the fire door.
- Remove the fuel retaining bar, by lifting free of the retaining slots.
- Set the rear liner (s) into the back of the firebox.
- Lift the throat plate into position with the front above the perforated air tube. Align the 2 tabs on the throat plate with the location slots in the rear air bar and drop into position (See Fig 5)
- Insert one of the side liner panels in each side at the back sitting on the side landing. Lift up one at a time past the throat plate as far as it will go and slide in the lower liner side liner. Repeat for the other set of rear side liners. (See Fig 3&4)
- Insert one front side liner in each side of the front of the stove. Secure in place with the front liner clamp as shown. (See Fig 3&4)

**Note: Neither the rear firebox liners nor the side firebox liners are 'handed', both faces are suitable for direct contact with the fire bed.**

**Note : Cracking of the liner panels does not effect efficiency.**

### Overall View Of Liners & Throat Plate Assembly

Fig 3 Throat plate sat correctly on air tube and rear air bar. Note: Insulation blanket not shown for clarity

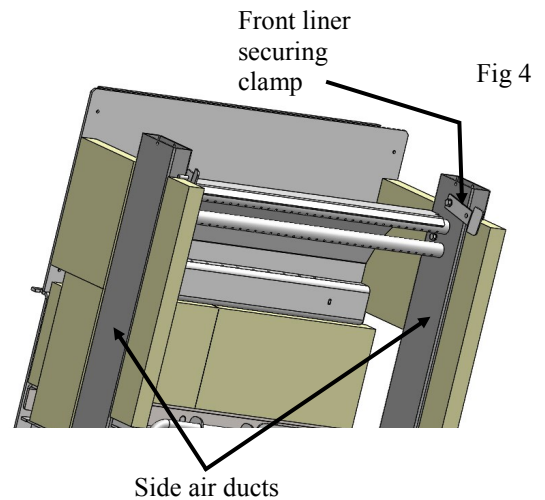
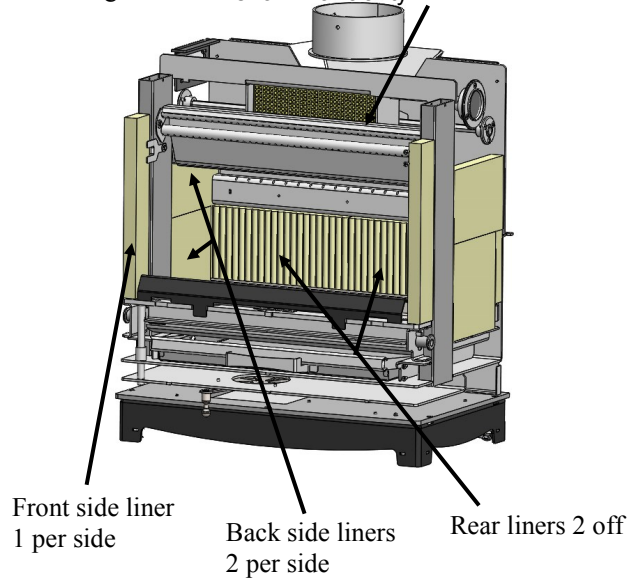
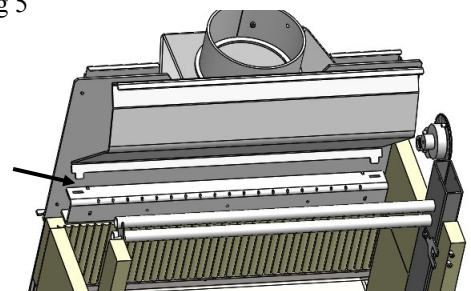

Fig 5

Throat plate location tab and slot in rear air bar



# INSTALLATION

## Catalyst Replacement

The catalyst in your Farrington 16 wood stove should be replaced after approximately 12000 hours of burning, or if you notice a darkening of the smoke omitted from your chimney.

The catalyst should be replaced every 5 to 6 years irrespective of hours burned.

Replace with only a genuine Arada Catalyst  
Part No. Detailed on page 33

The performance of the catalytic device or its durability has not been evaluated as part of the EPA certification

**Replace as detailed below.**

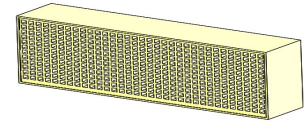

**Farrington Catalyst**  
P/No. CatFAR16.01

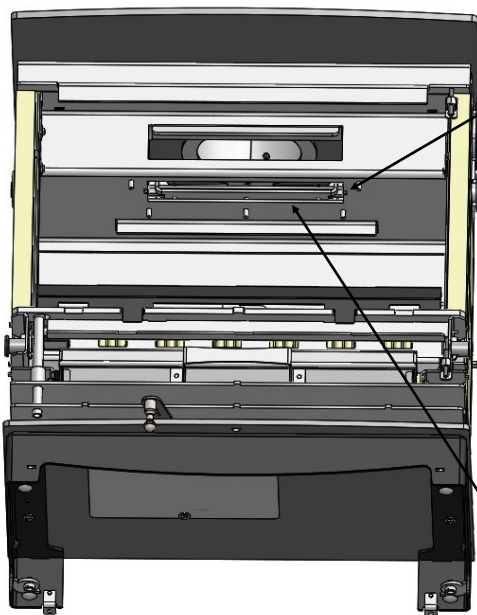

Remove the throat plate as detailed on page 19,  
Remove the 5 domed nuts and withdraw the catalyst cover and catalyst, Discard the old catalyst in accordance with local regulations.

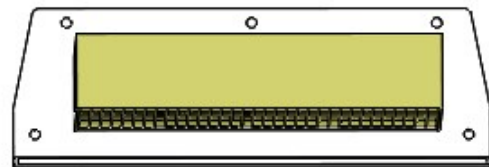

Sit the new catalyst on the cover plate as shown (approximately central) offer the cat and cover plate back up to the stove gently sliding the cat through the aperture. **Do not** remove the CatGard wrap or the white tape securing it in place, this forms the seal on first firing.

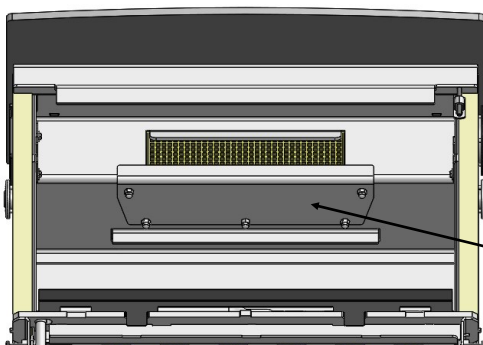

Replace and tighten the 5 domed nuts firmly but do not over tighten

Refit throat plate as detailed on page 19

## FINAL CHECK LIST

Before handing over the installation to the customer it is recommended that the appliance is lit and the functioning of the chimney system is checked for satisfactory operation.

- **Be sure that the chimney is operating and ALL smoke and fumes are vented to the atmosphere through the chimney terminal.**
- **Check all joints and seals.**
- **Clean the outside of the appliance to prevent any stains becoming burnt on.**
- **Check the flue draught which should read 1—2mm, or 0.1—0.2 mbar.**
- **Explain the controls and operation of the appliance to the customer.**

The following details **must** be checked and completed in full by the installer at the time of installation. Please answer all questions as fully as possible. **Arada stoves** cannot be held responsible for the chimney or installation.

## SUMMER STORAGE / NON USAGE

Please ensure that your stove is left clean and moving components are well lubricated for the summer months (during periods of prolonged non use). If possible store the throat plate outside of the stove, check all moveable components, at regular intervals, to ensure they are moving freely.

Allow air movement through the stove, by opening the primary air inlet control to about half way open or leave the door ajar. This will allow a free flow of air through the appliance thus preventing moisture and condensation forming inside the stove and chimney. This preventative maintenance will ensure your stove stays in the best condition for the coming winter months.

### MAINTENANCE

*It is important that your appliance is regularly serviced in accordance with these instructions.*

**Note: Only use original Arada components for service replacements, NEVER substitute parts for similar items**

*Service / repairs should be carried out at least annually by a qualified person and should consist of the following as a minimum:*

### CLEANING:

#### Do not clean the stove or door glass when hot

##### Important:

Establish a routine for the fuel, wood burner and firing technique. Check daily for creosote build-up until experience shows how often you need to clean to be safe. Be aware that the hotter the fire the less creosote is deposited, and weekly cleaning may be necessary in the mild weather even though monthly cleaning may be enough in the coldest months. Contact your local municipal or provincial fire authority for information on how to handle a chimney fire. Have a clearly understood plan to handle a chimney fire.

To clean and inspect your stove properly remove the firebrick linings and throat plate, inspect all rope gaskets on doors, glass etc, and re-order any items that may need replacing from your **Arada** dealer.

Sweep the chimney and confirm that it is sound. Examine all joints in the flue pipe etc, and re-seal if necessary. Re-assemble and leave with the air inlet and air wash control about half way open. This will allow a free flow of air through the appliance thus preventing moisture and condensation from building up inside the stove and chimney.

### CHIMNEY SWEEPING

Sweeping should be carried out with an appropriate sized bristle brush and rods to suit chimney size and type. As with all appliances regular sweeping of the flue is essential. Any existing chimney should be swept prior to installation of the appliance, and swept again a second time **within one month** of regular use after installation to establish frequency of sweeping required. This should be done by a competent person such as a chimney engineer who will provide a Certificate Of Chimney Sweeping.

The whole flue way including the outlet must be swept at least twice per burning season. It is important that the flue ways, flue pipe and chimney be cleaned prior to lighting the fire after a prolonged shut down period.

### DOOR GLASS

The door glass should remain clear during normal burning. However, under certain conditions, such as burning at a low rate or damp wood, the glass may become somewhat blackened. To remedy this, operate the appliance at a fast rate. Alternatively:-

#### WHEN THE STOVE IS COLD

open the door and clean the inside face of the glass with a damp cloth or with glass cleaner (available from fire stockists). A piece of cloth moistened with vinegar and dipped in wood ash will provide a good soft scourer to remove the soot without scratching the glass.

#### Do Not Use Abrasive Cleaners

#### Do Not operate with Broken Glass

**Do not operate with the fuel retainer not fitted as this may result in the fire being to close to the door glass**

### OUTER FINISH

The outer finish of the appliance is a durable high temperature paint. It is best cleaned, by brushing down, with a clean shoe brush. Do not allow moisture to remain on the appliance whilst cold or surface rust may form.

The high temperature paint should not require attention for some time, depending on use. The hotter the fire burns the sooner repainting will be necessary. Aerosol tins of paint are available for complete refurbishing.

Before repainting make sure that the fire is out and the stove is cold.

- Remove the door glass
- Lightly wire brush, or rub with wire wool, the body of the appliance to remove any loose paint or rust.
- Mask or remove items such as brass work.

**Re-spray in a well ventilated area, avoid breathing the vapour. Refer to safety instructions on paint cans.**

- Leave the appliance for eight hours before lighting a fire.
- Burn slowly for the first four hours, then build up heat slowly to gradually cure paint.

## SERVICE & MAINTENANCE

---

### FIRE DOOR ROPE REPLACEMENT

Periodically, visually check over the fire door rope seal for any damage, cuts or tears and any detached sections. It is important to maintain these seals in good condition at all times

The rope gasket can be replaced, using the universal rope kit (Available from Arada), please follow the instructions below :

- Ensure the appliance is cold.
- Lift the door off the appliance and lay onto a flat surface with the rear face upwards.
- Carefully remove the old rope gasket and old adhesive. Take note of the layout of the old rope seal. Ensure no traces of the old adhesive or rust / flaky paint is present, as this will result in a unsound joint.
- Apply the rope adhesive following the instructions on the bottle.
- Press the rope gasket into the channel on the rear of the door casting, following the same layout as the old rope seal. See Fig. 8.
- Just before the final end, cut the rope seal to length and glue into position.
- Allow 30 minutes, before refitting the door to the appliance.

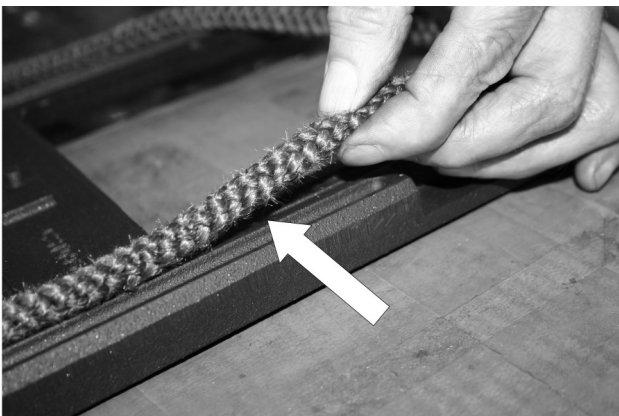

**Fig. 8. Rope Replacement**

**Note: Images fig 8 & 9 for reference only**

### FIRE DOOR GLASS REPLACEMENT

In the event of the door glass being broken it can easily be replaced. Please follow :

- The door should be lifted off the hinges so that the operation can be carried out on a work bench or similar level surface.
- Unscrew the four screw fixings, securing the glass clips and remove, both clips and fixings.
- Carefully remove any pieces of broken glass, and sealing gasket, wearing suitable gloves as protection. Take note of the position and joint of the rope gasket.
- Replace the glass rope gasket; start at the bottom of the window, centrally, push the adhesive side of the rope into the groove on the rear of the casting. Gradually work your way around until the end of the rope meets. See Fig. 9.
- Re-seat the new glass, ensuring the glass sits flat against the gasket. See Fig. 10.
- Replace the four retaining clips and fixing screws. Do not over tighten the fixings as damage may occur to the glass. See Fig.11.
- Refit the door assembly back onto the stove; carefully lift the door over the hinge and slot into place.

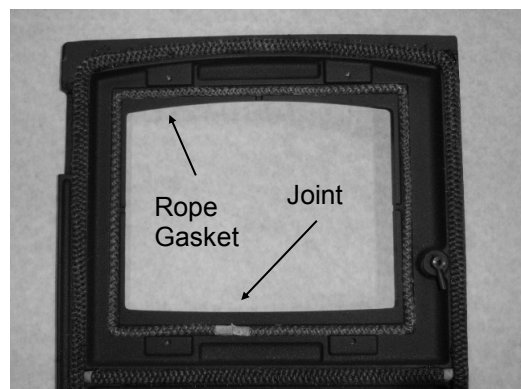

**Fig. 9. Lining Up Gasket Rope**

**Please Note:**  
***This should be carried out when the stove is cold and unlit.***



**Fig. 10. Positioning The Glass**



**Fig. 11. Tightening The Glass Clip**

The images used on pages 22 and 23 illustrating the door rope and glass replacement are generic images and may differ from the stove you have, but the procedure is identical.

**Use only genuine Arada 5mm Neocrem Ceramic glass as detailed in the parts list shown on page 30. ( Size 484mm wide x 368mm high )**

**Do not substitute with any other material type or size.**



# OPERATING INSTRUCTIONS

---

## FUEL :

### SAFETY NOTICE

The most efficient use of this appliance is with the fire door closed at all times, apart from re-fuelling (when alight) or cleaning (when cold). NEVER leave the appliance unattended for an extended length of time with the door open.

**WOOD**— Any type of wood is suitable provided it is well seasoned and has a moisture content below 20%. This usually implies that the timber has been suitably stored to allow moisture to evaporate for at least nine months in the case of soft woods, and at least eighteen months in the case of hard wood.

**Do not exceed the maximum log length detailed in the technical data table on page 9**

**WARNING :** wet wood must not be used as this will greatly contribute to the creation of tar and creosote which may, in extreme cases, run down the chimney in liquid form. This will seriously damage both the chimney and the appliance, and increase the risk of a chimney fire.

### FUEL STORAGE:

*Bulk wood fuel should be stored so as to be kept dry with a good air circulation.*

*Fuel kept local to the heater for convenient use must not be stored within installation clearances to combustibles ( see pages 16-18 ) or in the space required for charging or ash removal*

*Please Note : If you have sticky tar inside the appliance or chimney your wood is 'Green' or too wet.*

*Please Note : The burn classification for all appliances in these instructions are classed as intermittent use.*

Never use gasoline, gasoline-type lantern fuel, kerosene, charcoal lighter fluid or similar liquids to start or 'freshen up' a fire in this heater. Keep all such liquids well away from the heater while in use.

### Important:

Never use any type of liquid fuel to start or refresh your stove and keep all such fluids well away from the stove when in use.

**NEVER BURN CHARCOAL IN YOUR STOVE.** Charcoal can produce high levels of Carbon Monoxide, a *highly toxic* gas.

## Do not burn:-

- 1, Garbage;
- 2, Lawn clippings or yard waste;
- 3, Materials containing rubber, including tires;
- 4, Plastic or Materials containing plastics;
- 5, Waste petroleum products, paints or paint thinners, or asphalt products;
- 6, Materials containing asbestos;
- 7, Construction or demolition debris;
- 8, Railroad ties or pressure-treated wood;
- 9, Manure or animal remains;
- 10, Salt water driftwood or other previously salt water saturated materials;
- 11, Unseasoned wood; or
- 12, Paper products, cardboard, plywood, or particleboard. The prohibition against burning these materials does not prohibit the use of fire starters made from paper, cardboard, saw dust, wax and similar substances for the purpose of starting a fire in an affected wood heater. Burning these materials may result in release of toxic fumes or render the heater ineffective and cause smoke.

## LIGHTING THE STOVE

**Prior to lighting the stove for the first time, check with the installer that :**

- The chimney is sound and has been swept and is free from obstruction.
- Adequate provision for combustion air has been made, i.e. a permanent vent of at least 550mm sq per KW of rated output above 5KW, is fitted in the room in which the appliance is installed. That Local Building Codes have been followed during installation. See installation section of this manual.
- All firebox liner panels, throat plate and insulation blanket are in place.
- That the chimney draw has been checked and is within specification. With the chimney warm, the draught should be between 1-2 mm water gauge or 0.1 to 0.2 mbar.

**ENSURE THAT YOU HAVE READ & UNDERSTOOD THESE INSTRUCTIONS BEFORE LIGHTING THE FIRE.**

**ALWAYS WEAR SUITABLE PROTECTIVE FIRE GLOVES WHEN REFUELLING YOUR STOVE.**

**DO NOT OPERATE THE STOVE WITH CRACKED OR BROKEN DOOR GLASS.**

---

**The Farringdon 16 is *NOT* designed to burn any type of coal**

---

## OPERATING INSTRUCTIONS

---

### BURNING WOOD

- Set the fire by using rolled up newspaper and place a layer of dry kindling wood on top of this.
- Use 2 or 3 fire lighters to light the kindling.
- Set the primary air control to the fully open position. See page 28.
- After the kindling has caught light, you may leave the fire door ajar by about 20mm. If required to aid flue draw (Initial lighting on a very cold day for example)
- The flue draw should be established after 5 minutes, and the kindling well burnt down to form an ember bed.
- Carefully load the stove with a little more kindling and well seasoned wood.  
**Avoid building up fuel close to the fire door glass.**  
**Keep fuel behind the fuel retainer well inside the firebox, and then close the fire door**
- After 5 minutes, regulate the Primary air control, typically reduce to approximately half way.
- Refuel as necessary

The exact position of the air control will vary according to installation factors and some experimentation will be required to acquire the optimum position for burning

The primary air control (Left) should be used to vary the burn rate. 3/4 open will produce approximately 16 kwh for a 4.5kg load (1 hour burn time to refuelling) dependant on fuel quality and moisture content.

**No attempt should be made to alter the air control adjustment range to increase firing for any reason**

**Do not charge the stove with more fuel than the firebox limit of 6kg of wood**

*Please Note : The high temperature paint acquires durability by being "cured" during the initial firings of the appliance. It will give off fumes which are non toxic, but certain persons may find they have an unpleasant or irritant effect. Ensure that the surrounding area is well ventilated during this time.*

*Please Note : To avoid chimney problems your appliance should not be burnt at a reduced burn rate without a period of fast burning.*

### Smoke Detectors:

**It is always advisable to have a smoke detector fitted in the room where the wood stove is installed**

Smoke detectors may be affected if small amounts of smoke are released into the room during re-fueling. To avoid this always open the air supply control to maximum for a few moments prior to opening the fire door to refuel.

This will allow time for sufficient heat to build up within the firebox to clear and smoke still present in the lower portion of the flue/connector pipe.

### Note:

**Do not operate this stove with the fire door open other than for re-fuelling or de-ashing**

**Take care to avoid damaging the door glass by excessive slamming of the door, or striking with hard objects.**

**WARNING :** Properly installed, with a suitable flue or chimney, operated and maintained correctly, this appliance will not emit fumes into the dwelling. Occasional fumes when de-ashing and re-fuelling may occur. However, persistent fume emission is potentially dangerous and must be investigated by a registered expert installer.

**Stop using the appliance if you smell fumes or see smoke escaping.**

**If fume emission does persist, the following immediate actions should be taken :**

- Open doors and windows to ventilate room.
- Let the fire die or extinguish and safely dispose of fuel from the appliance.
- Check for flue or chimney blockage, and clean if required.

**Seek expert advice**

# OPERATING INSTRUCTIONS

## OVER FIRING & CHIMNEY FIRES

**DO NOT OVER FIRE THIS HEATER.** Using flammable liquids or too much wood or firing the stove at maximum for prolonged periods or operating with **fire doors open** may result in over-firing. If the chimney connector or casing glows red the appliance is being over-fired this may result in permanent damage to the stove and a chimney fire. If this occurs :

- **Call the Fire Service**
- **Immediately close all of the air inlets to the appliance, to reduce the air supply to the stove.**
- **Move items of furniture and combustibles away from the stove, to reduce a risk of fire and to allow access for the fire service.**
- **Ensure access to the loft space is available.**
- **Evacuate the property.**
- **An uncontrolled burn or excessive temperature indicates excessive draft.**

The chimney fire may cause structural damage to the chimney. Do not use the appliance until the chimney and connector have been inspected and any damaged parts have been repaired or replaced. This should be done by a registered engineer.

Attempts to achieve heat output rates that exceed heater design specifications described in this manual can result in permanent damage to the heater and to the catalytic

**See page 38 for further details**

## ASH REMOVAL

The appliance will require ash to be removed periodically but an ash bed of approximately 20mm (3/4") should be maintained. Ash may be removed with a small shovel whilst the fire is still lit by raking the embers of a low fire to one side of the firebox and carefully removing the ash, then repeating the procedure for the other side. Care must be taken not to risk burning of hands or household objects from falling embers.

The ash pan should be emptied when the level of ash reaches the top of the ash pan. On no account should the ash be allowed to build up to touch the underside of the grate bars, as this will greatly reduce the life span of the grate.

When burning wood it is acceptable to maintain an ash bed on top of the grate of approximately 20mm (3/4") without any un-due effect upon the grate bars.

## Ash Disposal.

Ashes should be placed in a metal container with a tight fitting lid. The closed container of ashes should be placed on a non-combustible floor or on the ground, well away from all combustible materials, pending final disposal. If the ashes are disposed of by burial in soil or otherwise locally dispersed, they should be retained in the closed container until all cinders have thoroughly cooled

## TO EMPTY THE ASH PAN

The Farringdon stove is supplied with a unique ash pan. To empty or remove the ash pan, open the fire door, wearing a safety glove, draw out the ash pan and unfold the lifting handle of the ash pan and remove from the ash pit chamber.

Empty the ash into a suitable steel container with a tight fitting lid and moved outdoors immediately, Other waste should not be placed in this ash container

Replace the ash pan into the stove and close the fire door.

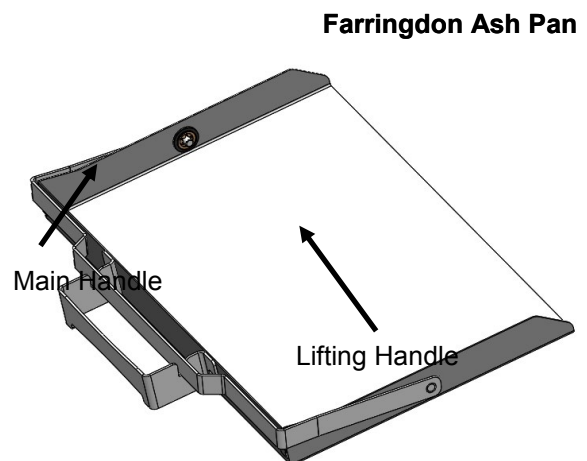

# OPERATING INSTRUCTIONS

---

## AIR INLET CONTROL

The Arada Farringdon 16kw stove air inlet control.

The primary air inlet provides the main air supply to the fuel and the **airwash** system through the control slider located under fire door on the **Left** side. Placed fully to the **LEFT** is Low air, and to the **RIGHT** is High air. The air wash system, so called because its pre-heated high speed air, washes across the inner face of the door glass, keeping it clear. This also provides an over draught to the fuel bed. For combustion of the wood fuel

## PRIMARY AIR

Air enters the appliance through the control at the bottom of the fire door. The Arada Farringdon has a single control slider sliding left to right.

**See Fig A & B below**

**Note:**

**The air supply does not fully close intentionally**

The exact position of the air control will vary according to installation factors and some experimentation will be required to acquire the optimum position for burning

The primary air control (Left) should be used to vary the burn rate. 3/4 open will produce approximately 16 kwh for a 4.5kg load (1 hour burn time to refuelling) dependant on fuel quality and moisture content.

Operation at continuously low burn rates will increase the production of tar and other residues building up in the flue and chimney and should be avoided.

Fig A

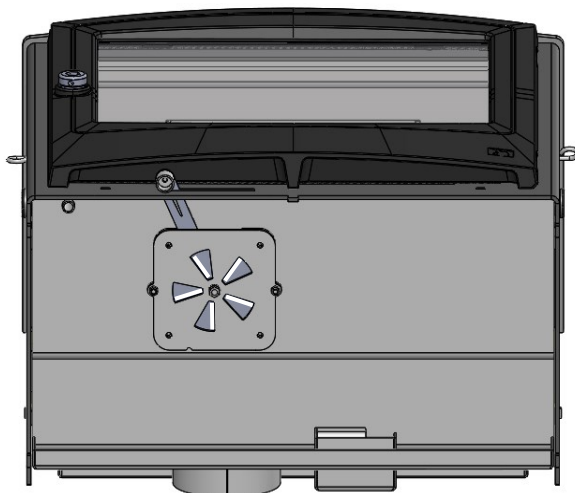

**Minimum Closed Position**

Fig B

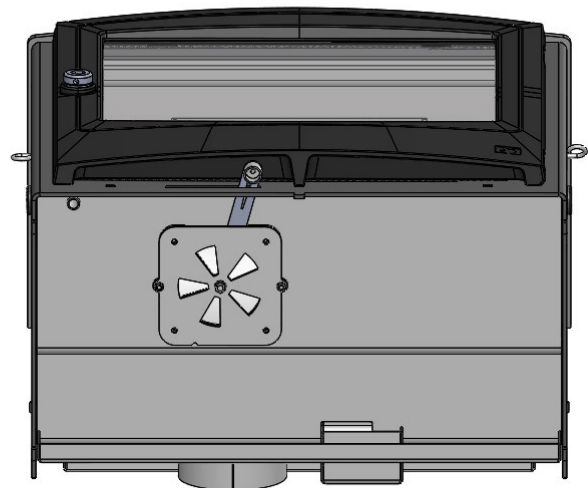

**Fully Open Position**

# OPERATING INSTRUCTIONS

## Catalyst

The Arada Farrington 16kw stove is fitted with a ceramic catalyst to aid clean burning.

The catalyst should be inspected for damage annually and if necessary replaced. The catalyst part number can be found in the parts list on page 33.

**Only replace with a genuine Arada Catalyst ( Details on page 20 )**

### Catalyst Bypass Control.

The control for the catalyst bypass is on the left and right side of the stove in the position shown in Fig A.

Actuation is as shown on the label on the right hand side. The bypass should be placed in the open position during the lighting stage and prior to opening the door for re-fuelling.

The Catalyst will be active when the thermometer indicates 300°C or above, the bypass door should then be closed. The stove should be run with sufficient combustion air to maintain a temperature above this level to ensure proper catalyst function. During re-fuelling or initial lighting the bypass should remain open until the minimum light-off temperature of 300°C is reach/re-established

The door/riddling tool is used to control the bypass by insertion into the tri-lobed boss.

Always run the stove with the bypass door closed during normal burning phase.

See Fig C & D for cutaway image of bypass actuation

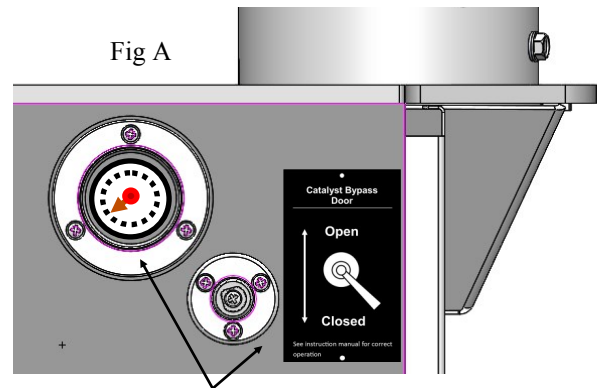

### Stove thermometer

The stove thermometer indicates when the stove is at the correct temperature to close the by-pass door for normal running, and re-open for re-fuelling and/or lighting, See Fig B



Fig C

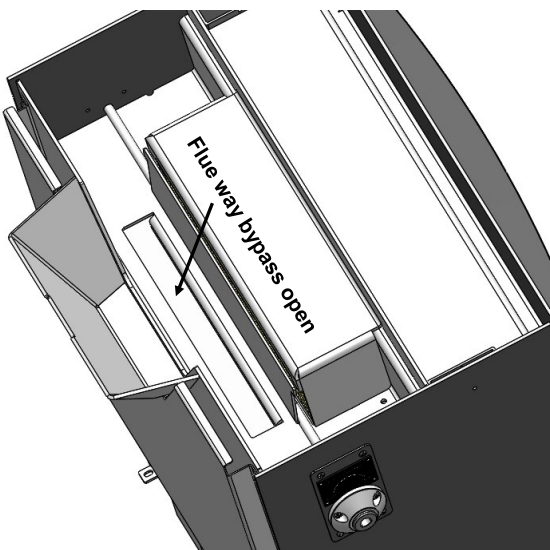

Open Position (Cat bypassed)

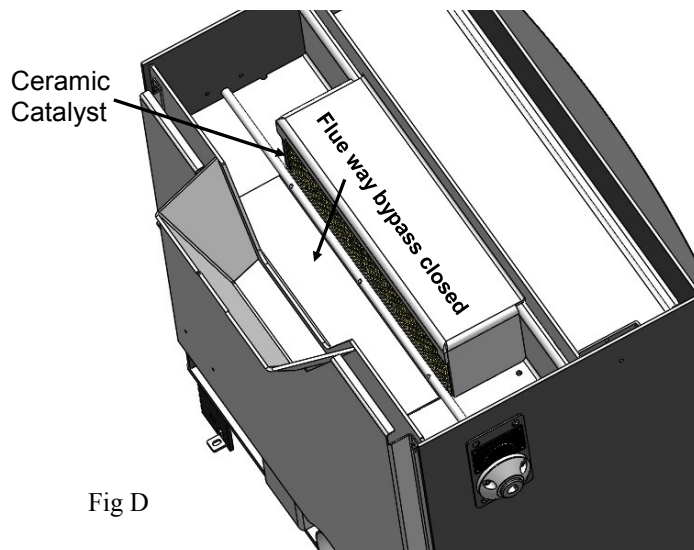

Fig D

Closed Position

# OPERATING INSTRUCTIONS

---

## MAIN FIRE DOOR HANDLE

A stove mitten is supplied with your Arada Farrington stove, this is provided for the operation of the fire door handle whilst the stove is in use. Care must be taken when opening and closing the fire door as any surrounding areas of the stove will be very hot.

**WARNING** : Never attempt to open the fire door whilst the appliance is in use WITHOUT the use of the stove mitten or suitable gloves, serious injuries may occur.

Caution must be given when re-fuelling the appliance, always keep the stove mitten away from naked flames and sparks.

The fire door handle can also be used to operate the riddle mechanism, sockets located on either side of the stove body. This is to aid ash removal by agitating the ash bed and allowing it to drop into the ash pan below.

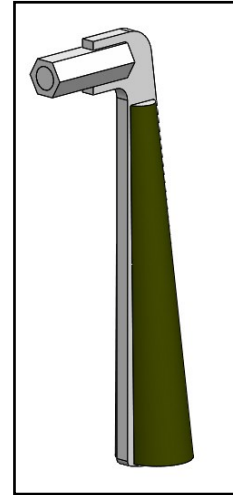

**Fire Door Handle (Oak cladding)**

### The Main Fire Door Handle

This handle can reach 100°C +  
Always use a stove mitten

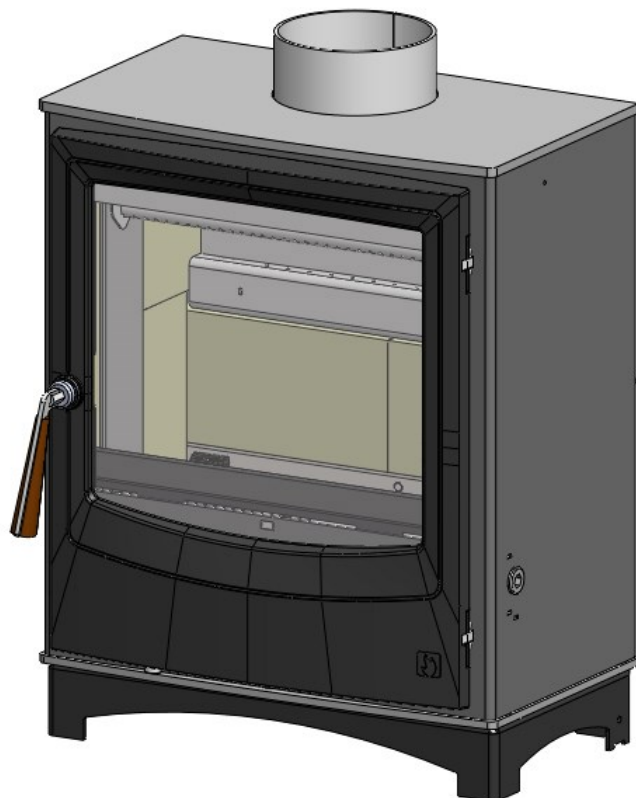

# PARTS LIST

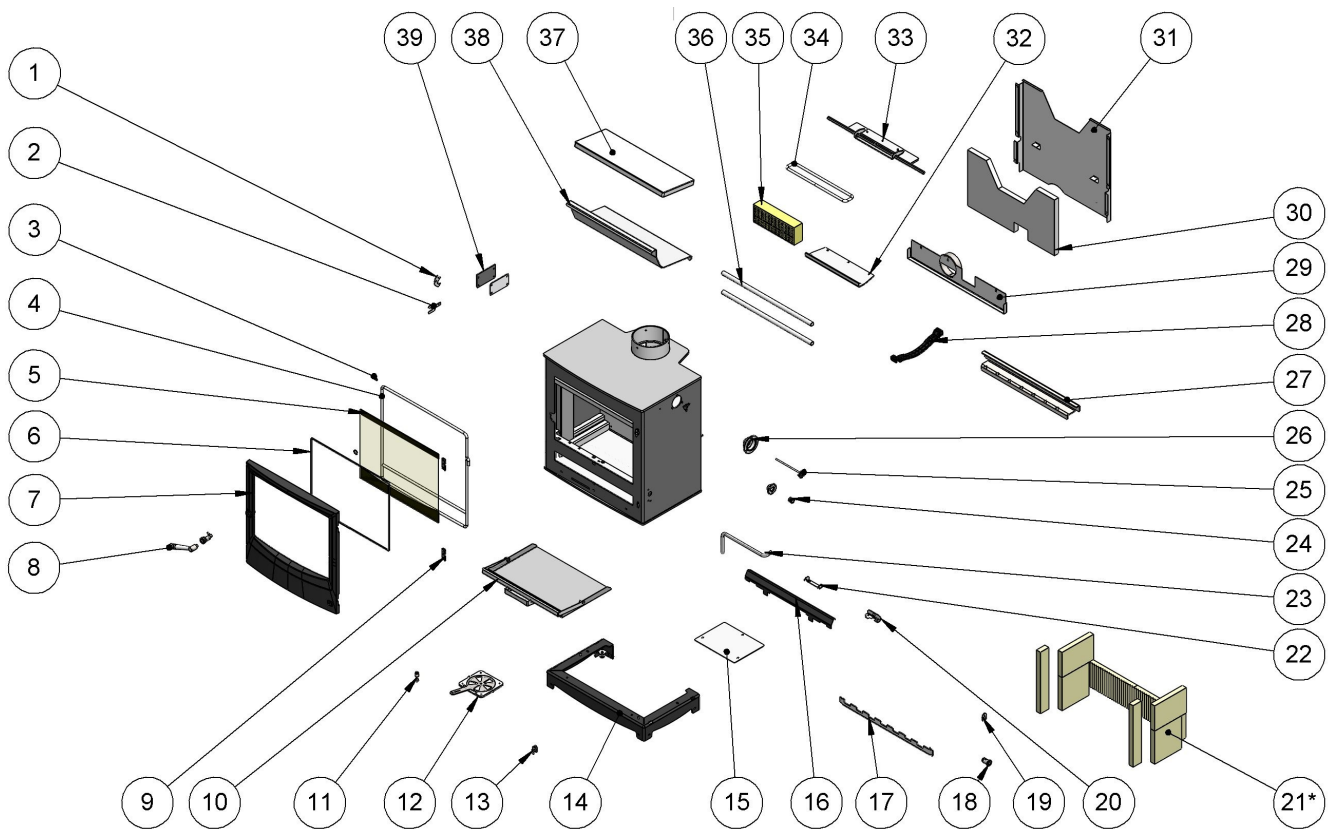

No.	Description	Part Number	No.	Description	Part Number
1	Airwash Tube Clamp	AFS3655	21c	Side Liner (Top Rear)	TBA
2	Liner Fastener	TBA	21d	Side Liner (Bottom Rear)	TBA
3	Glass Clips	AFS1010	22	Pilot Tube Clamp	AFS3720
4	Rope Kit	ARA019	23	Pilot Tube	TBA
5	Glass Kit	AFS4130	24	Gland Plate & Bypass Lever	TBA
6	Gasket & Glass Clips	AFS1361	25	Catalytic Thermometer	TBA
7	Complete Fire Door	TBA	26	Thermometer Bracket	TBA
8	Handle Assembly	AFS4015	27	Grate Bar Support	TBA
9	Hinge Catch Plate	AFS3865	28	Grate Bar	AFS2025
10	Ash Pan	TBA	29	Direct Air Adaptor	TBA
11	Air Control Knob	AFS3860	30	Heatshield Insulation	TBA
12	Air Slider Assembly	AFS4190	31	Heatshield	TBA
13	Hinge	AFS3690	32	Catalyst Door	TBA
14	Farrington Feet	TBA	33	Bypass Damper Assembly	TBA
15	Base Air Cover	AFS4185	34	Bypass Door Rope	TBA
16	Fuel Retainer	TBA	35	Catalytic Convertor	CatFAR16.01
17	Comb	TBA	36	Air Wash Tube	TBA
18	Comb Extension	AFS4005	37	Blanket	TBA
19	Clevis Lock	AFS3720	38	Throat Plate	TBA
20	Pilot Tube End Bracket	AFS3725	39	Access Hatch & Seal	TBA
21a	Fluted Rear Liner	TBA			
21b	Side Liner (Front)	TBA			

Farringdon 16 (USA—EPA Specification Only)

# GUARANTEE

---

## Arada Stoves – MANUFACTURER’S LIMITED WARRANTY

### Effective 1<sup>st</sup> January 2017

The warranty policy applies to wood-burning products identified by the Arada and Aarrow trade names only.

Arada Stoves warrants that each stove body will be free of material defect for a period of 10-years from the date of original purchase. If a product is proved to contain a defective component, Arada Stoves will, at its sole discretion authorise repair or replace the defective part at Arada Stoves expense. Arada Stoves will not be responsible for any associated costs incurred by the owner as a result of loss of use.

The stove must have been purchased from an authorised Arada Distributor or Dealer. All products or component parts for which a warranty claim is being made must be returned (at the owners cost) to an authorised Arada distributor or dealer for inspection. If upon inspection, the damage is found to be the fault of the manufacturer, Arada Stoves will either repair the defective part or replace the defective part free of charge and send it to the authorised distributor or dealer.

This 10-year limited warranty is non-transferable and is extended only to, and is solely for the benefit of the original purchaser of the stove. Please retain your dated sales receipt as proof of purchase.

This limited 10-year limited warranty covers repair or replacement of defective body parts ONLY; it does not cover any associated labour or transport costs.

## EXCLUSIONS AND LIMITATIONS

### This 10-year limited warranty does not cover the following:

1. No warranty is extended to internal consumable parts, such as (but not limited to) baffle plates, baffle assemblies, grate-bars, fuel retainers, grate assemblies, firebricks/vermiculite liners, glass panels, ash pans, and sealing materials such as sealing rope. It is expected that such parts will be exposed to normal wear and tear and will require replacement from time to time.
2. Damage as a result of poor installation and usage other than as described in Arada’s installation and operation instructions or if the installation does not conform to local building and fire and safety codes.
3. Handle components or assemblies.
4. Damage caused by over-firing or over-heating (as described in the operation manual). Warping and a red-oxide colouring will demonstrate the over- heating of internal parts; body paint which has turned dusty white is also indicative of such use.
5. Defects or faults caused by local conditions such as draft problems and chimney defects.
6. Damage caused by the use of the wrong fuel type.
7. Arada stoves modified by the user or any companies other than Arada are not covered under this guaranteed
8. Costs relating to the removal, repair or re-installation.
9. Parts supplied by any manufacturer other than Arada.
10. Catalyst element (Cat FAR16 01 )

### Arada Stoves – MANUFACTURER’S LIMITED WARRANTY Cont:-

11. Damage caused by modifications, inappropriate use or repair
12. Damage incurred while the stove is in transit; this should be claimed against the shipper or freight carrier. Contact the authorised dealer from whom you have purchased your stove. (Do not operate the appliance as this may negate the ability to process the claim with the carrier)
13. Any Damage caused by not following the servicing and maintenance schedule as set out in the operation manual.

#### Limited 1-year warranty:

- The stove must be installed in precise accordance with the official Arada instruction and operating manual and local building codes and fire and safety regulations.
- Repaired or replaced products are covered only for the remainder of the original warranty period.

Glass is warranted against damage resulting from thermal shock only, for a 12 month period from date of purchase.

In no event shall Arada Stoves be liable for incidental or consequential damages, injury to persons, property, or any other consequential loss.

Some States do not allow the disclaimer or limitation of damages so you should consult the laws of your State to determine if this limitation applies to you.

#### DISCLAIMER OF IMPLIED WARRANTIES

The foregoing limited warranty is exclusive and in lieu of all other warranties, guarantees, agreements and similar obligations of manufacturer or seller. Arada Stoves hereby disclaims all warranties implied by state law, including the implied warranties of merchantability and fitness for a particular purpose.

Some States do not allow implied warranties to be disclaimed. In that event, the implied warranties that cannot be disclaimed are hereby limited to the shortest duration allowed by the applicable state law. This warranty gives you specific legal rights, and you may also have other rights by state law, which vary from State to State.

If you believe your Arada Stove is defective you should return the defective part/stove at your expense together with the original proof of purchase and stove serial number to the place of purchase. If upon inspection the product is deemed to have a manufacturing defect, an official warranty claim will be processed on your behalf.



### Fuel:

The Farringdon 16 is suitable for **wood burning** only  
Use any untreated well seasoned wood with a moisture content below 20%

### Combustible:

Le Farringdon 16 est conçu pour ne brûler que du bois. Utiliser du bois non-traité et séché avec un pourcentage d'humidité inférieur à 20%.

### Never burn:-

Any type of coal, charcoal, liquid fuels, garbage plastic or any other household waste  
Further details can be seen on page 26.

### Ne jamais utiliser :

Tous types de charbons, combustibles liquides, débris, plastique ou tous autres déchets ménagers.  
Plus d'explications en page 26.

### Combustion air control :

Optimum settings are as follows..  
The primary air control (on the left below the door) should be used to vary the burn rate. 3/4 open will produce approximately 16 kwh for a 4.5kg load (1 hour burn time to refuelling) depending on fuel quality and moisture content.

### Contrôle de l'air pour la combustion :

Les paramètres optimaux sont les suivants:  
Le contrôle de l'air primaire (sous la porte, à gauche) est utilisé pour faire varier le taux de combustion. Si l'arrivée d'air est ouverte aux 3/4, le poêle produira environ 16 kwh pour un chargement de 4.5Kg de bois (pendant une heure jusqu'à rechargement), selon la qualité du combustible et sa teneur en humidité.

### Catalyst Combustor:

The Farringdon 16 combustor part number is **CatFAR16.01** only replace with a genuine Arada replacement combustor. This is available from your local Arada agent/stove supplier, information and address details can be found on our web site as follows: [www.aradastoves.com](http://www.aradastoves.com)

### Chambre de combustion catalytique :

La chambre de combustion catalytique du Farringdon 16 porte le numéro de pièce de rechange **CatFAR16.01**. Utilisez seulement une pièce de rechange authentique Arada, disponible chez votre revendeur agréé. Adresses et détails sont disponibles sur [www.aradastoves.com](http://www.aradastoves.com).

### Checking your combustor:

Inspect your combustor before each heating season  
Light grey ash and darker granular material will gradually build on the combustor surface and should be removed along with any sooty deposits. This should be done using a clean paint brush and vacuum cleaner. If any cells are blocked clean them through with a cotton swab or pipe cleaner.  
Do not scrape the surface of the combustor with a hard scraper or knife as this may cause damage.

### Vérifications de la chambre de combustion :

Inspectez votre chambre de combustion avant chaque saison de chauffage. De la suie, de la cendre gris-clair et de la matière granuleuse se déposent graduellement sur la surface de la chambre de combustion et doivent être retirés en utilisant un pinceau propre et un aspirateur. Si des alvéoles sont bouchées, nettoyez-les avec un coton-tige ou un cure-pipe. Ne raclez pas la surface de la chambre de combustion avec un objet dur ou un couteau, cela pourrait l'endommager.

## A USER QUICK REFERENCE GUIDE

---

### Cont.:-

#### Replacement:

If the stove is operated in accordance with the instructions within this manual you combustor should last 5 to 6 years, (or approximately 12000 hrs of burn time)

The following symptoms would indicate it's time to renew the combustor:-

Decreased heat output for known fuel load and air settings

Sluggish draw from your chimney, (other causes -  
- investigated and ruled out)

Increased chimney smoke, (other causes -  
- investigated and ruled out)

The procedure for removing and refitting the combustor are found on page 20 of this manual.

If the combustor is found to be completely blocked with creosote or in other ways damaged and has to be replaced, **Do not operate the stove without a new catalyst fitted.**

#### Warning:

**BURN UNTREATED WOOD ONLY. OTHER MATERIALS SUCH AS WOOD WITH PRESERVATIVES OR PAINT COATINGS, METAL FOILS, ANY TYPE OF COAL, PLASTIC, GARBAGE, SULPHUR OR OIL MAY DAMAGE THE CATALYST AND REQUIRE IST REPLACEMENT.**

#### Remplacement :

Si le poêle est utilisé conformément aux instructions dans cette notice, votre chambre de combustion doit pouvoir être utilisée pendant 5 ou 6 ans. (ou approximativement 12000hrs de combustion)

Les symptômes suivants peuvent indiquer qu'il est temps de remplacer votre chambre de combustion :

Production de chaleur réduite pour une quantité de combustible et un réglage de l'air connus.

Tirage paresseux du conduit (autre raison recherchée et exclue)

Production accrue de fumée par la cheminée (autre raison recherchée et exclue)

La procédure pour retirer et remplacer la chambre de combustion se trouve en page 20 de cette notice.

Si la chambre de combustion se trouve complètement bouchée par la créosote ou endommagée et qu'elle doit être remplacée, **N'utilisez pas le poêle sans qu'un nouveau catalyseur soit installé.**

#### Attention :

**NE BRÛLER QUE DU BOIS NON-TRAITÉ. TOUT AUTRE MATÉRIAU COMME LE BOIS RECOUVERT DE PEINTURE OU CONTENANT DES CONSERVATEURS, LES EMBALLAGES MÉTALLIQUES, TOUS TYPES DE CHARBON, PLASTIQUE, DÉTRITUS, SOUFRE OU PÉTROLE PEUVENT ENDOMMAGER LE CATALYSEUR ET NÉCESSITER SON REMPLACEMENT.**

## CATALYST ADDITIONL INFORMATION

---

It is important to periodically monitor the operation of the catalytic combustor to ensure that it is functioning properly and to determine when it needs to be replaced. A non-functioning combustor will result in a loss of heating efficiency, and an increase in creosote and emissions.

Following is a list of items that should be checked on a periodic basis:

Combustors should be visually inspected at least three times during the heating season to determine if physical degradation has occurred. Actual removal of the combustor is not recommended unless more detailed inspection is warranted because of decreased performance. If any of these conditions exists, refer to installation section on the catalyst on page 21 of this manual.

This catalytic heater is equipped with a temperature probe to monitor catalyst operation (see page 31).

Properly functioning combustors typically maintain temperatures in excess of 500 °F (260 °C), and often reach temperatures in excess of 1,000 °F (540 °C).

You can get an indication of whether the catalyst is working by comparing the amount of smoke leaving the chimney when the smoke is going through the combustor and catalyst light-off has been achieved, to the amount of smoke leaving the chimney when the smoke is not routed through the combustor (bypass mode).

Step 1, Light stove in accordance with instructions on page 27

Step 2, With smoke routed through the catalyst, go outside and observe the emissions leaving the chimney.

Step 3, Engage the bypass mechanism and again observe the emissions leaving the chimney. Significantly more smoke will be seen when the exhaust is not routed through the combustor (bypass mode).

Inspection is recommended at least 3 times during the heating season to ensure the catalyst is in good order. Signs of cracking or blocking of the catalyst will require its replacement, further information can be found on page 37 of this manual.

Details on checking and replacing can be found on pages 27 and 31 of this manual, pay close attention to the use of the bypass door described in detail on page 31 of this manual.

---

## Final Factory Check list



Stove Model .....
Serial No. ....

Quality / Finish	
Grate bars (14)	
Fuel Retainer	
Firebox Liners (8)	
Throat Plate	
Throat Plate Insulation Blanket	
Door / Riddle Handle	
Ash Pan	
Operating & Installation Manual	
Stove Mittens	
Ceramic Catalyst ( 1 off fitted )	

***I've checked it  
and its O.K !***

Assembled By.....

Checked by.....

Date of Purchase.....

Name and Address of Supplier.....

.....

.....

---

Arada Ltd  
The Fire Works  
Weycroft Avenue  
Axminster  
Devon  
EX13 5HU  
United Kingdom

Tel: +44(0)1297 35700 Fax: +44(0)1297 35900 [www.arada.uk.com](http://www.arada.uk.com)